

Panasonic Telephone Systems



www.voicesonic.com
Phone 877-289-2829

Panasonic

DBS 576
Digital Business System

Technical Manual

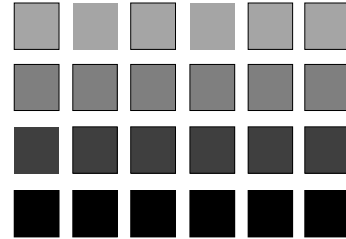

Section 200 General Description

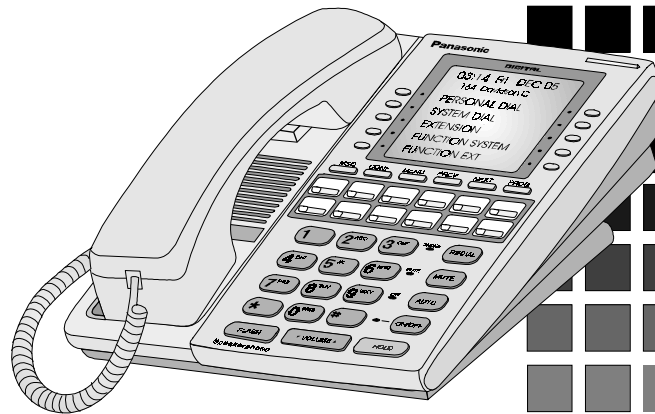
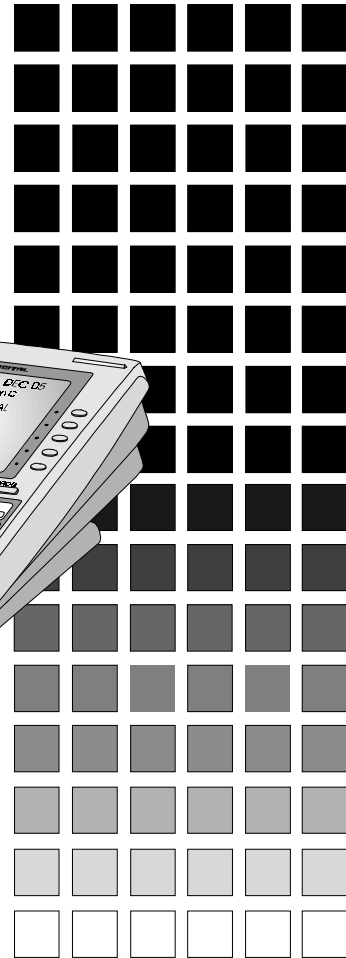

USA

DBS 576 - Version 2.5
issued March 1999

**Panasonic Telecommunication Systems Company
Business Telephone Systems Division**

The contents of this document are subject to change without notice and do not constitute a commitment on the part of Panasonic Telecommunication Systems Company (PTSC). Every effort has been made to ensure the accuracy of this document. However, due to ongoing product improvements and revisions, Panasonic cannot guarantee the accuracy of printed material after the date of publication, nor can it accept responsibility for errors or omissions. Panasonic will update and revise this document as needed.

The software and hardware described in this document may be used or copied only in accordance with the terms of the license pertaining to said software or hardware.

Reproduction, publication, or duplication of this manual or any part thereof, in any manner mechanically, electronically, or photographically, is prohibited without permission of PTSC.

© copyright 1998 by Panasonic Telecommunication Systems Company (PTSC)
a division of Matsushita Electric Corporation of America

All rights reserved.

Win32s, Windows, Windows 95, and Windows NT are either trademarks or registered trademarks of Microsoft Corporation in the United States and/or other countries.

Reference to third-party products is for information only and does not constitute an endorsement or recommendation. Panasonic does not assume responsibility for the performance of third-party products.

Preface - Requirements

OVERVIEW

This section provides information the telephone company may require before providing you with service. Additionally, important notices and warnings are listed for your knowledge and safety.

FCC REGISTRATION NUMBERS

The Federal Communications Commission (FCC) has established rules which permit the DBS 576 to be directly connected to the telephone network. To ensure that the DBS 576 complies with these FCC rules, the local telephone company may ask you for the FCC registration numbers when attaching their equipment to the DBS 576.

The DBS 576 can be configured as either a KEY or Hybrid telephone system. The way you register your system depends on how you use the system. First, determine how you will be operating the system, and then refer to the table below for FCC registration numbers. The following tables also list additional information that may be required by your local telephone company.

Key Operation

A KEY system requires you to manually select an outside line to make an outgoing call. Typically, line keys on a telephone represent the specific lines that are attached to the system (for example, Key 1 represents line 1; Key 2 represents line 2; etc.).

Hybrid Operation

A Hybrid system allows automatic selection of outgoing lines, such as pooled key operation, dial access, least cost routing (LCR), etc. (for example, depress a key to select from a pool of lines; or dial 9 to select an outside line).

REGISTRATION INFORMATION

System	Operation	Ringer Equivalence	Network Address Signaling Code	FCC Registration
DBS 576	KEY	Loop Start: 0.5B/2.8DC* DID: 0.0B*	E	JNVUSA-32340-KF-E
DBS 576	HYBRID	Loop Start: 0.5B/2.8DC* DID: 0.0B*	E	JNVUSA-32339-MF-E

* The Ringer Equivalence Number (REN) is useful to determine the quantity of devices that you may connect to your telephone line and still have all of those devices ring when your number is called. In most, but not all areas, the sum of the RENs of all devices on any one line should not exceed five (5). To be certain of the number of devices you may connect to your line, as determined by the REN, you should call your telephone company to determine the maximum REN for your calling area.

INTERFACE INFORMATION

The DBS 576 offers several types of interface cards that allow you to connect to different circuits offered by your telephone company. Listed below is additional information that the telephone company may require before providing you with these different services.

REGISTRATION INFORMATION

Port Type	Type of Interface	USOC Jack Connector	Service Order Code	Facility Interface Code
Loop Start Trunk	2-wire loop	RJ21X	9.0F	02LS2
Ground Start Trunk	2-wire ground	RJ21X	9.0F	02GS2
DID Trunk	2-wire DID	RJ21X	AS.2	02RV2-T
T-1 Trunk	T-1	RJ48C	6.0P	04DU9-DN, 04DU9-1SN
ISDN	PRI	RJ48C	6.0P	04DU9-DN, 04DU9-1SN
ISDN	BRI	RJ48C	6.0P	02IS5
E&M	Type I 2-wire Type I 4-wire Type II 2-wire Type II 4-wire Type V 2-wire	RJ1CX	9.0F	TL11M, 2-wire TL31M, 4-wire TL12M, Type II 2-wire TL32M, Type II 4-wire -- (European standard)

DIRECT INWARD DIALING (DID) REQUIREMENTS

Operating this equipment in a manner that does not provide for proper answer supervision is a violation of Part 68 of the FCC Rules. Proper answer supervision occurs when:

- (A) this equipment returns answer supervision to the Public Switched Telephone Network (PSTN) when DID calls are:
 - answered by the called station
 - answered by the attendant
 - routed to a recorded announcement that can be administered by the Customer Premise Equipment (CPE) user
 - routed to a dial prompt.
- (B) this equipment provides answer supervision on all DID calls forwarded to the PSTN. Permissible exceptions are:
 - A call is unanswered.
 - A busy tone is received.
 - A reorder tone is received.

T-1 REQUIREMENTS

This device must only be attached to the T-1 network connected behind an FCC Part 68 registered Channel Service Unit (CSU). Direct connection is not allowed.

ADDITIONAL PRECAUTIONS

- This equipment may not be used on coin service provided by the telephone company. This equipment should not be used on party lines.
- If the unit appears to be malfunctioning, it should be disconnected from the telephone lines until you determine if either your equipment or the telephone line is the source of the problem. If your equipment needs repair, it should not be reconnected until it is repaired.
- If the telephone company finds that this equipment is exceeding tolerable parameters, the telephone company may temporarily disconnect service, although they will attempt to give you advance notice if possible.
- Under the FCC Rules, no customer is authorized to repair this equipment. This restriction applies regardless of whether the equipment is in or out of warranty.
- The goal of the telephone company is to provide the best service it can. In order to do this, it may occasionally be necessary for them to make changes to their equipment, operations, or procedures. If these changes might affect your service or the operation of your equipment, the telephone company will give you notice, in writing, to allow you to make any changes necessary to maintain uninterrupted service.
- This equipment is capable of providing users access to interstate provider of operator services through the use of access codes. Modification of this equipment by call aggregators to block access dialing codes is a violation of the Telephone Operator Consumers Act of 1990.
- If you experience trouble with the DBS 576, please contact your Panasonic DBS authorized service provider for repair/warranty information. The telephone company may ask you to disconnect this equipment from the network until the problem has been corrected.

FCC WARNING

THIS EQUIPMENT GENERATES, USES, AND CAN RADIATE RADIO FREQUENCY ENERGY, AND, IF NOT INSTALLED AND USED PROPERLY, THAT IS, IN STRICT ACCORDANCE WITH THE INSTRUCTION MANUAL, MAY CAUSE INTERFERENCE TO RADIO AND TELEVISION RECEPTION. THIS EQUIPMENT HAS BEEN TESTED AND FOUND TO COMPLY WITH THE LIMITS FOR A CLASS A COMPUTING DEVICE IN SUBJECT J OF PART 15 OF FCC RULES, WHICH ARE DESIGNED TO PROVIDE REASONABLE PROTECTION AGAINST SUCH INTERFERENCE IN A RESIDENTIAL INSTALLATION. HOWEVER, THERE IS NO GUARANTEE THAT INTERFERENCE WILL NOT OCCUR IN A PARTICULAR INSTALLATION. IF THIS EQUIPMENT DOES CAUSE INTERFERENCE, CORRECT BY ONE OR MORE OF THE FOLLOWING MEASURES:

1. REORIENT THE RECEIVING ANTENNA,
2. RELOCATE THE KEY SERVICE UNIT AND KEY TELEPHONES WITH RESPECT TO THE RECEIVER,
3. MOVE THE EQUIPMENT FROM THE RECEIVER,
4. PLUG THE KEY SERVICE UNIT INTO A DIFFERENT OUTLET SO THAT THE EQUIPMENT AND RECEIVER ARE ON DIFFERENT BRANCH CIRCUITS.

BATTERY RECYCLING STATEMENT



The following statement applies if you purchased backup batteries with your system.

THE PRODUCT YOU HAVE PURCHASED MAY CONTAIN SEALED LEAD ACID BATTERIES WHICH ARE RECYCLABLE. AT THE END OF THEIR USEFUL LIFE, UNDER VARIOUS STATE AND LOCAL LAWS, IT IS ILLEGAL TO DISPOSE OF THESE BATTERIES INTO YOUR MUNICIPAL WASTE STREAM. PLEASE CALL 1-800-SAV-LEAD FOR INFORMATION ON HOW TO RECYCLE THESE BATTERIES.

IMPORTANT NOTICE: MUSIC-ON-HOLD SOURCE

In accordance with U.S. Copyright Law, a license may be required from the American Society of Composers, Authors and Publishers (ASCAP), or other similar organization, if radio or TV broadcasts are transmitted through the music-on-hold connection on this DBS 576 product. Panasonic Information & Communications Company/ Business Telephones Systems Division, hereby disclaims any liability arising out of failure to obtain such a license.

DBS 576 General Description (Section 200)

Table of Contents

PREFACE - REQUIREMENTS	3
Overview	3
FCC Registration Numbers	3
Key Operation	3
Hybrid Operation	3
Interface Information	3
Direct Inward Dialing (DID) Requirements	4
T-1 Requirements	4
Additional Precautions	4
FCC Warning	5
Battery Recycling Statement	5
Important Notice: Music-On-Hold Source	5
CHAPTER 1 - SYSTEM OVERVIEW	11
Introducing the Next-Generation Phone System from Panasonic	11
System Technology	13
Power Requirements	14
Diagnostic Maintenance	14
Programming the Phone System	14
Supporting Documentation	15
CHAPTER 2 - SYSTEM HARDWARE	16
Overview	16
Cabinets	16
Common Cards	16
Telephone Company Interface Equipment	16
Station Interface Equipment	16
Optional and Miscellaneous Equipment	16
Station Equipment	16
System Hardware Connections	16
Cabinets	18
Base Cabinet (VB-44020)	18
Expansion Cabinet (VB-44021)	19
-48V Cabinet Power Supply (VB-44022)	19
Battery Backup (VB-44025)	19
Switch Box (VB-44023)	19
Control Unit Processor Cards	20
Control Processor Card (96-port) - CPC-96 (VB-44410)	20
Control Processor Card (288-port) - CPC-288 (VB-444201)	20
Control Processor Card (576-port) - CPC-576 (VB-444301)	20

Time Switch Card - TSW-288 (VB-444202)	21
Time Switch Card - TSW-576 (VB-444302)	21
Building Block Expansion Cable Kit - CBL (VB-44451)	21
DBS 576 to DBS Expansion Cable Kit - CBLDBS (VB-44452)	21
Network Synchronizing Unit - SYNC (VB-44460)	22
Trunk/Tie Line Cards	22
Loop Start Trunk Card - LTRK/8 (VB-44510)	22
Loop Start/Ground Start Trunk Card - LGTRK/8 (VB-44511)	22
Caller ID Unit - CID (VB-44513)	22
ISDN Primary Rate Interface Card (T/S-point) - PRI/23 (VB-44540)	22
ISDN Basic Rate Interface Card (T-point) - TBRI/4 (VB-44530)	22
E&M Trunk Card - E&M/4 (VB-44560)	22
DID Trunk Card - DIDTR/8 (VB-44520)	23
T-1 Interface Card - T-1 (VB-44550)	23
Trunk MDF Interface - MDF-CO (VB-44512)	23
Extension Cards	23
Digital Extension Card - DEC/8 (VB-44610)	23
Analog Extension Card - AEC/8 (VB-44520)	23
ISDN Primary Rate Interface Card (T/S-point) - PRI/23 (VB-44540)	24
ISDN Basic Rate Interface Card (S-point) - SBRI/4 (VB-44630)	24
Extension MDF Interface - MDF-EXT (VB-44611)	24
Options	24
Service Circuit Card - SCC (VB-44181)	24
DTMF Multi-Frequency Receiver Card - MFR/8 (VB-44110)	24
Power Failure Transfer Unit (VB-43703)	24
Conference Card (4 circuits) - CONF (VB-44120)	24
Application Processor Interface Card - API (VB-44131)	25
Built-In ACD Card - ACD (VB-44140)	25
Built-In Voice Storage Card - VSSC (VB-44170)	25
Voice Processing Card (4 circuits) - VPU/4 (VB-44160)	25
Voice Processing Card (8 circuits) - VPU/8 (VB-44150)	25
Station Equipment	26
Overview	26
Model Options	27
Model Descriptions	27
Digital Single Line Telephone (DSLTL)	27
16-Key Standard Phone	27
22-Key Standard Phone	28
22-Key Small-Display Phone	28
22-Key Small-Display Phone with Voice Response	28
22-Key Large-Display Phone	28
34-Key Standard Phone	29
34-Key Small-Display Phone	29
24-Key Expansion Module (EM/24)	29
72-Key Direct Station Select/Busy Lamp Field Module (DSS/72)	29
Optional Terminal Devices	30
Voice Recognition Unit Adapter (VB-44101)	30
PC Phone (VB-44332)	30
PC Attendant Console/96 (VB-44330)	30
PC Attendant Console/384 (VB-44331)	30
Telephone Key Layout	31

CHAPTER 3 - SYSTEM FEATURES	35
Overview	35
Popular System Features	35
AEC Disconnect	35
Attendant Groups	35
Auto Day/Night Mode	35
Automatic Route Selection (ARS)	36
Call Traffic Reporting	36
Caller ID	36
Class of Service (COS) Restriction	37
Conferencing	37
CTI (Computer Telephony Integration)	37
Data Security	38
Delayed Ringing	38
DISA (Direct Inward System Access)	38
Distinctive Ringing	39
Flexible Dial Plan	39
Flexible Ringing Assignment	39
“Howler” Tone	40
Hunt Groups	40
Multiple Direct Inward Dial (DID) Assignment	41
Recall Timers	41
Slide Ringing	41
Station Message Detail Recording (SMDR)	42
System Speed Dialing (SSD)	43
Toll Restriction Service (TRS)	44
Walking TRS	44
List of Available System Features	45

CHAPTER 4 - STATION FEATURES	48
Overview	48
Popular Station Features	48
Account Code Capability	48
Alarm Ringing	49
Alarm Tone for Lengthy Calls	49
Auto-Repeat Dialing	49
Background Music (BGM)	49
Busy Override (“Barge-In”)	50
Call Duration Display	50
Call Forwarding	50
Call Park	51
Call Pick-up	51
Callback Request	52
Camp-On (Call Waiting)	52
Do-Not-Disturb (DND)	52
DP-to-DTMF Signal Conversion	52
DSS/BLF Keys	53
Dual-Color LEDs	53
Flexible Feature Keys (“FF-Keys”)	54

Hands-Free Answerback	54
Headset Capability	54
Hold	55
Hot Dial Pad	55
Hot Line	55
Meet-Me Answer	56
Message-Waiting/Callback	56
Mute	56
Name Assignment	56
Off-Hook Monitoring	57
Off-Hook Signaling	57
Off-Hook Voice Announce (OHVA)	57
On-Hook Dialing	58
One-Touch Keys	58
Paging	58
Prime Line Preference	58
Ringing Line Preference	59
Soft Key Variable Mode	59
Speed Dialing	59
Transfer	59
Walking TRS	60
List of Available Station Features	60

CHAPTER 5 - SPECIAL APPLICATIONS **63**

Overview	63
Private Networking	63
Computer Telephony Integration (CTI)	64
PC Phone	64
PC Attendant Console	65
Voice Mail	66
Built-In Voice Mail with 2-Way Call Recording	66
Panavoice -- Panasonic's Digital Voice Mail System	67
Third-Party Voice Mail Support	67
Voice Mail Transfer Keys	67
MSG Key	67
One-Touch Key for Voice Mail	68
Answer Supervision for Voice Mail	68
DID to Voice Mail	68
Follow-Along Identification	68
Positive Disconnect	68
Automatic Call Distribution (ACD)	69
Built-In ACD	69

CHAPTER 6 - SPECIFICATIONS **70**

Overview	70
Electrical Characteristics	70
Power Supply	70

Battery Backup	70
Environmental Requirements	71
Temperature and Humidity Requirements for System Operation (excluding Built-In Voice Mail)	71
Temperature and Humidity Requirements (Built-In Voice Mail operation only)	71
Dimensions and Weight for Single-Cabinet Systems and Telephones	71
Resource Maximums	72
Line Capacities	72
Feature-Related Capacities	72
Hardware Maximums	74
Cabling Specifications	76
Maximum Cabling Distances	76
Voice/Data Transmission	77
Voice Path from Digital Keyphones to the DBS 576	77
Data Communication Ports	77
Modem Speed Throughput	77
Signaling Characteristics	78
Signaling to CO	78
Transmission Specifications	78
DTMF Frequencies	78

Chapter 1 - System Overview

INTRODUCING THE NEXT-GENERATION PHONE SYSTEM FROM PANASONIC

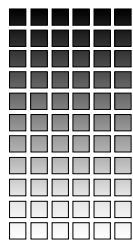

Our telephony customers know what they're looking for ...

real product solutions to meet the very real demand for an effective, responsive, user-friendly communications system. They know that their phone system is a kind of "welcome mat" to the outside world -- and their most important link to it.

To provide them with such a phone system, they need a company who's already out there on the front lines. With a solid reputation for reliability. Flexibility. Feature-rich options. Expansion capability. New technology, smartly applied. And all of this at an affordable price.

We hear you, loud and clear.

At Panasonic, we're one of the world's largest electronics companies. We've established a worldwide reputation for solid reliability and innovative design in all of our products. As a result, we've become a major world-class manufacturer of electronic telecommunications products.

Panasonic is already one of the largest suppliers of business telephone systems in the U.S. With our popular line of Digital Business System (DBS) telephone switches for small- to medium-size businesses, we've developed a reputation for providing cost-effective digital technology, dependable functionality, and user-oriented design. Our current U.S. customer base includes hundreds of authorized dealers, over 1,200 certified technicians, and nearly 1 million users.

And we're listening to them. They want a phone system that can expand beyond its current capacities to accommodate a larger phone base. They're asking for ISDN. Computer Telephony Integration. Automatic Call Distribution. Two-Way Call Recording. Video-Conferencing. Networking. Voice Recognition. And other advanced technology that will help them keep a competitive edge in today's (and tomorrow's) extremely competitive marketplace.

We've made it better.

As a result, Panasonic is proud to introduce the next-generation phone system in the DBS product line: the **DBS 576**. It's a robust, feature-rich, flexible, reliable phone system that can grow with the company it serves. At the best price/performance combination available.

Here are just a few of the cutting-edge features of this new Key/PBX system:

- Supports a larger phone base.**
The DBS 576 is expandable from 0 to 576 ports.
- Simple cabinet structure.**
The two types of cabinets - base and expansion - have exactly the same card slot structure, so there's no confusion about where to install cards. Many of the parts in these two cabinets are also the same.

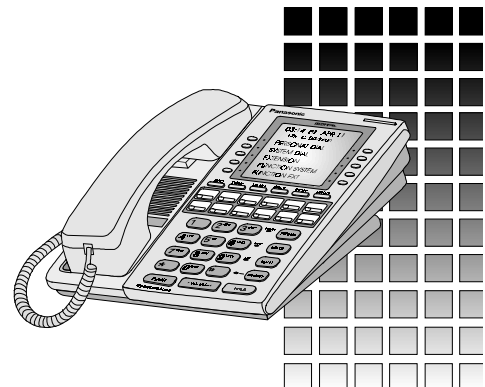

❑ **Universal ports.**

The DBS 576 offers flexible slot configuration. You can mount Trunk or Extension Cards in any of the 12 Free Slots in the cabinet. With this built-in flexibility, you can design the system the way you want it: efficiently, cost-effectively, whichever way makes the most sense. (In other words, YOU control the system -- the system doesn't control you.)

❑ **Seamless expansion capabilities.**

Start out with one cabinet to begin with, then pile on more cabinets later as your business expands. The expansion will be transparent, except for the fact that you'll suddenly be able to plug in more phones. You won't have to re-program the entire system when you add on, either (just the new additions). This expansion design allows you to pay for what you need today, while allowing for future expansion tomorrow.

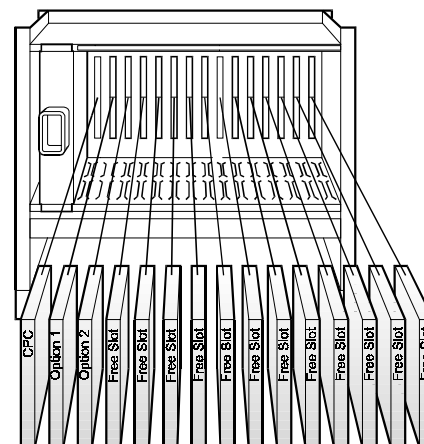

❑ **Flash memory upgrades.**

No more chip change-outs. No more complicated hookups. No more waiting forever to download/upload from the phone system. The DBS 576 phone system can be upgraded in a handful of minutes with a small diskette known as a PCMCIA card. Simply plug it onto the processor card, and perform a few simple programming steps. That's all there is to it: the system now contains the latest-and-greatest software release.

❑ **Simple expansion for existing PBX users.**

For current owners of DBS phone systems, we've designed the new switch so that you can expand the system you already have (without having to chuck the whole thing and start from scratch) into the new DBS 576. All of your existing telephones can be used with it. Even some of the cabinets and circuit cards from the old DBS can still be used.

❑ **Voice Recognition phones.**

With these special phones and DBS 576 technology, users can literally *tell* their phones what to do. Instead of dialing your home phone number, for example, press the Voice Recognition key and say, "Home." The phone will automatically call your house. Or press the same key and say, "Jeff." The phone will call Jeff for you. The future is right here.

❑ **Dynamic Bandwidth Allocation for ISDN digital switching.**

The DBS 576 provides the ability to allocate bandwidth on demand to several different sources, via hardware installations of special ISDN adapters. This powerful technology can be used to perform different applications from a single phone outlet. It means you can do video-conferencing, data transmission, multiple phones, voice, etc. - all from the same station position.

In fact, the DBS 576 offers full **ISDN support**, with both BRI (Basic Rate Interface) and PRI (Primary Rate Interface) capability. ISDN provides fully digital signaling, combines voice and data into one signaling system, and supports large-bandwidth applications such as video-conferencing.

❑ **Computer Telephony interface capability.**

We've developed proprietary software for several Computer Telephony applications, in which the desktop phone and the PC computer merge together into a single entity. The merger works like this: #1) Install a special board inside the computer. #2) Install our software in Windows. #3) Plug the phone's handset into the board. #4) Plug the board into the phone jack. Presto! you can now click-and-drag call transfers, monitor the status of other extensions, generate your own call traffic reports, and many other tasks you couldn't do before on your desktop computer.

Panasonic offers two **PC Console applications for the Attendant position**. One is a low-end product (supports up to 96 extensions) and the other is high-end (up to 384 extensions). The PC Console controls the system's calls from the computer, and the attendant can watch everything on the PC monitor.

Panasonic also offers proprietary software for a **PC Phone**, which replaces the desktop extension phone. End-users can control their own phone calls using the computer.

❑ **Networking services.**

The DBS 576 offers several ways to set up networking -- tying multiple DBS 576 systems together through the public switching network. **E&M Tie Lines** let you connect directly to another DBS 576 system using a leased voice line. **T-1 Networking** lets you tie multiple systems together through the network, so that (for example) when one location closes for the day, its calls can be picked up by another location across the country. A user can also turn a long-distance call into a local one by accessing another location and then dialing the number as a local call.

The system can also be set up in a **Tandem (T-1 Network)** environment, adding further benefits to the users at each location. For example, each switch can analyze the number dialed, and automatically route the call to other locations, extensions, or go through another location's switch to place a local call.

❑ **Automatic Call Distribution.**

With the DBS 576's Built-in ACD option, calls can be automatically distributed to the least-busy extension first, or on a next-available-extension basis. If the extension doesn't answer the call, you can program the system to continue searching, transfer to a particular extension, transfer to Voice Mail, or disconnect the call. You can control what the caller hears while he/she is waiting. Supervisors can instantly access the current status of all agents right from their desk using a Large-Display telephone - no need for costly computer programs to provide "real-time reporting." MIS reports can also be generated. For even more sophisticated functionality, Panasonic is releasing an Enhanced ACD version in the near future, with CTI support and enhanced call routing/reporting capabilities.

❑ **2-Way Call Recording.**

This is another Built-in option with the DBS 576. Users can record phone conversations, and store them (like voicemail messages) in their mailboxes.

System Technology

The DBS 576 is a completely digital system. Information is exchanged between the major system components using Pulse Code Modulation (PCM). The conversation exchange between digital telephones is also digital, converting the digital information to analog just before it reaches your handset or speaker.

Stored Program Control (SPC) is accomplished via 16-bit and 32-bit processors. This technology controls the powerful system features of the DBS 576. Each processor's customized memory (program settings) is backed up by an on-board, 6-year lithium battery.

The system provides maximum protection from outside power surges, with built-in triple surge protection for CO outside line connectors.

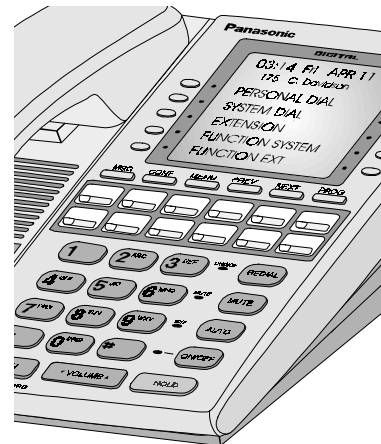

Power Requirements

The system must be connected to an input power source of 117V AC (+/-10%), 60 Hz. Each cabinet's power supply automatically generates 5V DC and 24V DC necessary to power the various printed circuit boards for station and peripheral equipment. Optional backup batteries are available, and are designed to safely fit into the cabinet. The power supply contains a charger that maintains a full charge to the backup batteries, which have a 3-year life and can support the phone system for up to 30 minutes at a time.

Diagnostic Maintenance

The printed circuit board (PCB) cards are designed to slide easily into slots within the DBS 576 cabinet. By using diagnostic troubleshooting, small problems can be isolated to specific cards. Some cards are designed to be installed and extracted from slots without turning off the power, allowing system maintenance to be completed without interrupting the entire system.

For example, say you're having a problem with one of the trunks on a Loop Start/Ground Start Trunk Card. Instead of having to turn off the power, or reprogram anything, or alert anyone to get off the phone, all you have to do is throw a Maintenance switch on the Card. This will busy-out the trunks on that Card that aren't being used at the moment, but will leave the trunks in use alone, allowing people to finish their phone calls without any disruption. The LEDs on the Card will tell you when the trunks become vacant. When all LEDs are extinguished, the Card can be replaced.

Programming the Phone System

Programming can be accomplished in several ways without disrupting normal phone system operation. Most programming changes take place as you are programming, what we refer to as "live" programming.

Programming from a display telephone.

Programming can be performed on any small-display or large-display extension phone. A large-display phone is recommended because its LCD buttons can perform special one-touch functions in programming (such as "stepping" through addresses, entering a pause in a speed-dial number, etc.). Only authorized access is allowed; you must enter a valid password to get into Programming mode.

Programming from the RS232 port.

A PC computer or laptop can be connected to the DBS 576 phone system, via a DB9-pin RS232 port on the SCC card inside the cabinet. Then, from the computer, you can program the phone system with our proprietary PC-based software, **PC Customized Tool**.

This popular software package runs in a Windows 95 environment and makes programming and maintaining phone systems easy and fun. With PC Customized Tool, multiple phone systems can be maintained in separate databases on the computer. The phone system parameters are grouped together in windows so you can see the current settings all on the same page. To set a parameter, simply click a button, or select from a multiple-choice field, or type in an entry. It even has context-sensitive help if you get stuck (press F1 and a help screen will pop-up, explaining the field you're in).

You can use PC Customized Tool to "build" a phone system, then download it into the phone system's memory all at once. Or you can perform individual, "live" changes to phone system memory from the computer. It can also be used for backing up and restoring phone system databases.

Programming from a remote location.

Again using PC Customized Tool, the DBS 576 can be programmed from a remote location, using an offsite computer terminal to call into the phone system. You can perform "live" changes in this manner as well as downloads/uploads (for backup/restoring).

Supporting Documentation

Panasonic provides extensive end-user documentation for the DBS 576 (all of which are available on our Web site for authorized dealers):

Section 511: 2-Way Call Recording User Guide (VB-44199; set of 25 Guides)

This is an end-user guide that contains step-by-step instructions such as accessing your mailbox, recording a message, etc.

Section 521: Built-In ACD Supervisor Guide (2 Guides provided with each ACD Card)

This is an end-user guide intended for the ACD Supervisor. It is a condensed version of the ACD Reference manual, and includes only the commands appropriate for the ACD Supervisor.

Section 700: Feature Operation (1 provided with each CPC Card)

This is a general operating reference guide for the DBS 576. It describes system and telephone features. It is designed for use by both the dealer and the end-user.

Section 720: SLT Phone Quick-Reference (8 provided with each AEC Card)

This is a quick-reference guide for Analog devices such as the SLT phone. It covers only the most commonly-used features, and is intended for the end-user.

Section 750: Digital Key Phone User Guide (VB-44299; 25 Guides + 25 Quick-Reference)

This is a general end-user guide for the 44-series Digital Key Telephone.

Section 751: Digital Key Phone/DSLIT Quick-Reference (25 provided in VB-44299 kit)

This is a quick-reference guide for Digital Key Telephones and DSLITs (Digital Single-Line Telephones). It covers only the most commonly-used features, and is intended for the end-user.

Section 770: Voice Recognition Telephone Adapter User Guide (1 provided with VR-AD)

This is a user guide describing the additional features of the Voice Recognition Telephone. It is intended for the end-user.

Panasonic®

DBS 576
Digital Business System

**The products you need. The services you deserve.
From the name you trust.**

Chapter 2 - System Hardware

Overview

This section describes the purpose and functionality of the main components of the system. By understanding how these components work, you can easily configure a system that meets your specific needs.

This section is divided into the following categories:

Cabinets

The DBS 576 cabinets are explained in detail below. Both the base cabinet and the expansion cabinet share the same PCB cards. Both cabinets can attach to any of the proprietary telephone sets offered by Panasonic. Each cabinet includes its own power supply, and is designed with dedicated slots for CPC and option cards, and free slots for trunk, extension, and built-in option cards.

Common Cards

The common cards control the signaling and features used by all other cards in the system. Without common cards, other cards cannot function. The common card which is considered the “brains of the system” is called the Central Processor Card, or CPC. Each phone system requires a processor to operate.

Telephone Company Interface Equipment

Panasonic offers a wide variety of interface circuits that allow the DBS 576 to attach to Central Office (CO) and/or common carrier equipment. This interface equipment is explained here in Chapter 2.

Station Interface Equipment

The DBS 576 allows for connection of Panasonic proprietary telephones as well as various analog telephones and devices provided by other manufacturers. This chapter includes descriptions of the cards and equipment needed to accomplish these connections.

Optional and Miscellaneous Equipment

The cards and interfaces that provide optional services, and all miscellaneous equipment, are explained later in this chapter.

Station Equipment

All Panasonic proprietary stations are explained later in this chapter.

System Hardware Connections

Shown on the next page is an illustration of DBS 576 trunk and extension line connections, as well as some of the more popular peripheral connections.

System Connections (trunks, extensions, peripheral equipment)

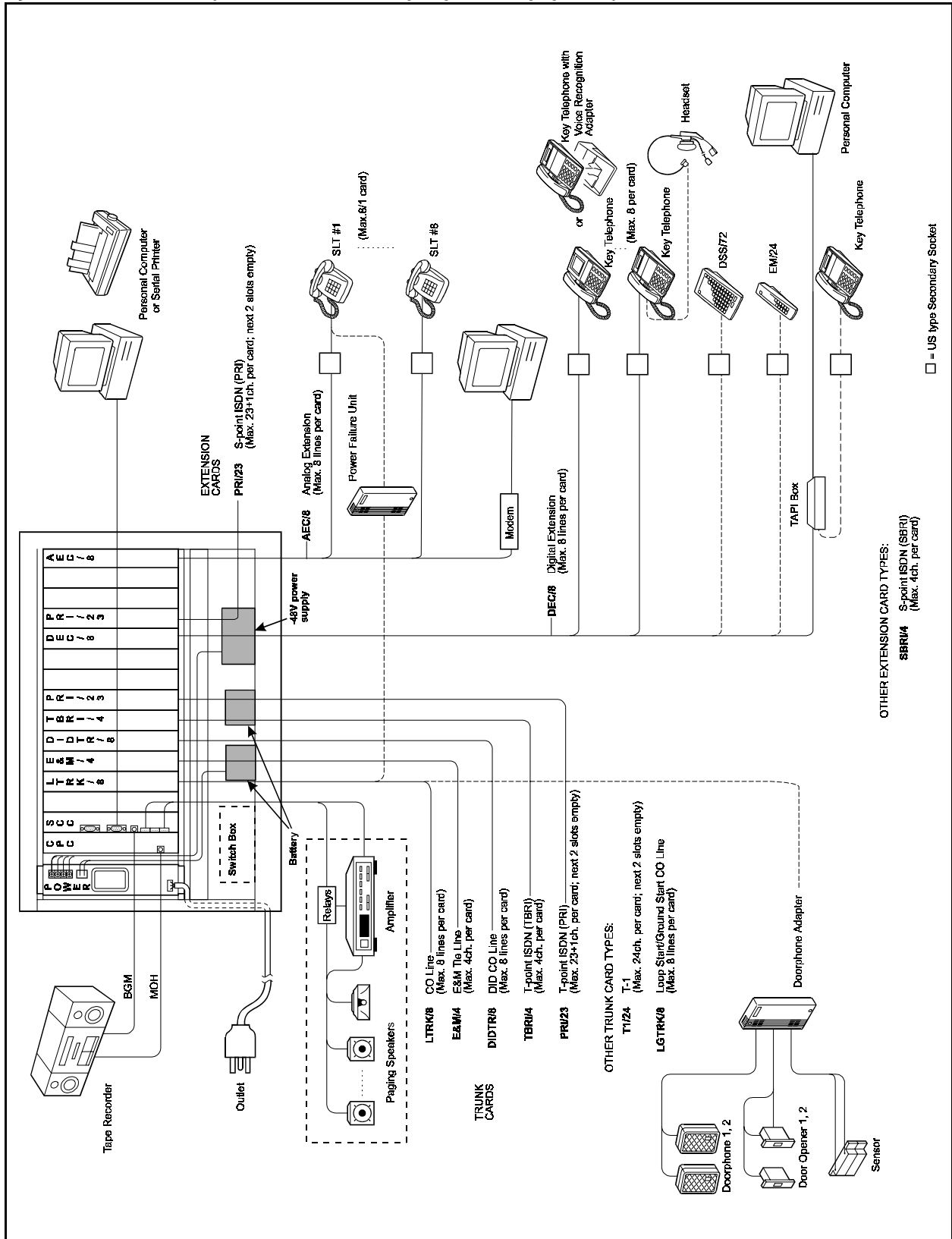

Cabinets

Two types of cabinets are used in the DBS 576:

- 1) the **Base cabinet**
- 2) the **Expansion cabinet**

Each cabinet provides 96 universal ports. Systems can be configured with one to six cabinets in a "building-block" fashion. The bottom cabinet in a column is the **Base** cabinet. The middle and top cabinets in a column must be **Expansion** cabinets.

The maximum configuration for a fully expanded (6-cabinet) system supports a maximum of 576 ports, and contains two Base cabinets and four Expansion cabinets (see figure below).

Maximum 6-Cabinet Configuration

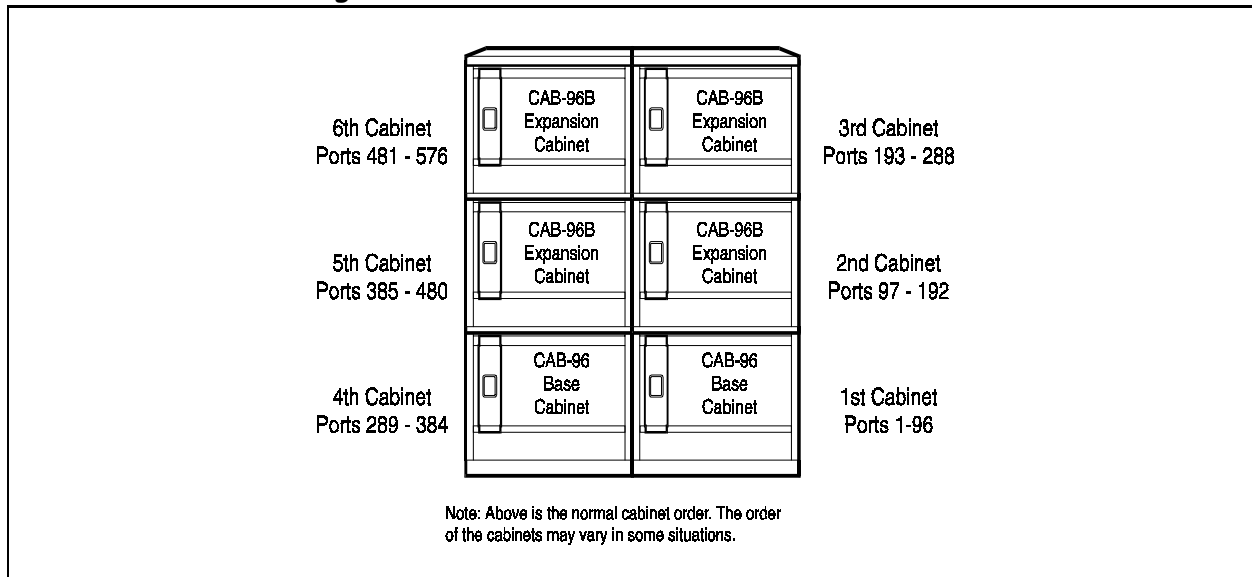

Base Cabinet (VB-44020)

Each Base cabinet supports up to 96 ports using flexible or universal card slots. Up to two Base cabinets can be installed in a system.

Multiple slot types are used in the Base cabinet. These slot types are as follows:

Slot type	# of slots	Unit type to be installed
Power slot	1	Accommodates the cabinet power supply. The power supply comes installed in the cabinet.
Main processor slot	1	CPC in first Base cabinet CBL (expansion interconnection card) in second Base cabinet
Flexible slots	12	For trunk cards, station cards, and other circuit cards.
Option slots	2	For optional cards such as SCC, TSW, and MFR/8.

Optional backup batteries can be installed for system operation in the event of a power failure.

The Base Cabinet

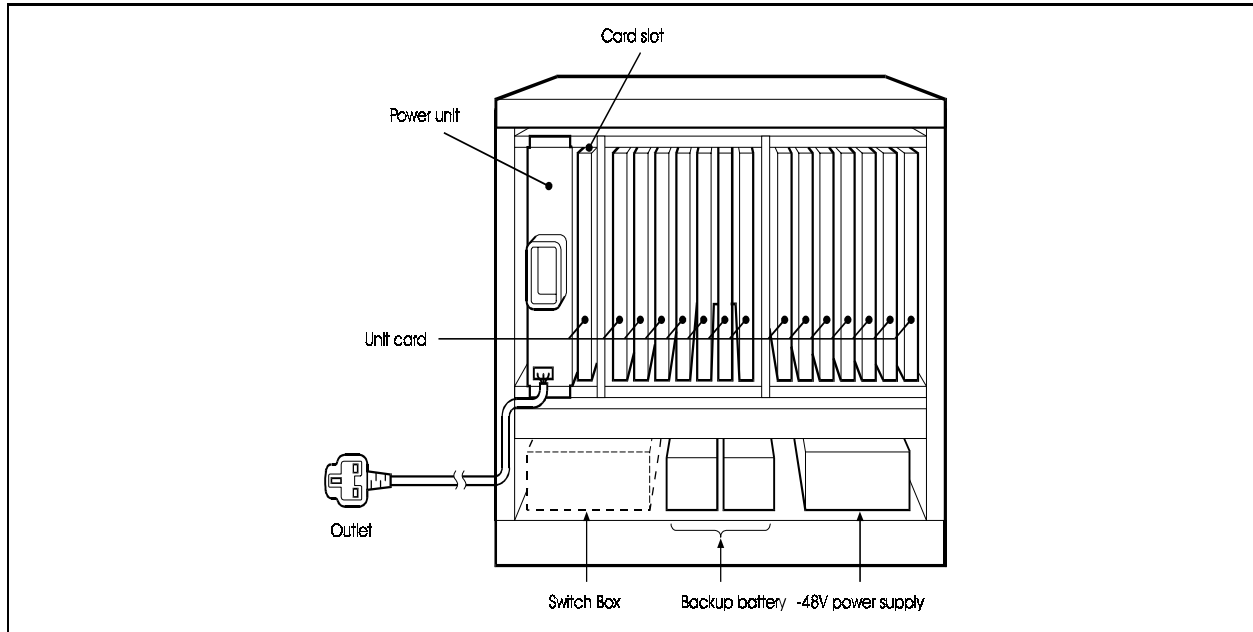

Expansion Cabinet (VB-44021)

Each added Expansion cabinet expands the system capability by an additional 96 ports. One or two Expansion cabinets can be installed on top of a Base cabinet. Up to four Expansion cabinets can be installed in a fully equipped, 6-cabinet system.

Multiple slot types are used in the Expansion cabinet. These slot types are as follows:

Slot type	# of slots	Unit type to be installed
Power slot	1	For the cabinet power supply (which comes installed in the cabinet).
CPC slot	1	For the cable expansion interconnection card.
Flexible slots	12	For trunk cards, station cards, and other circuit cards.
Option slots	2	For optional cards such as MFR/8.

NOTE: Optional backup batteries can be installed for system operation in the event of a power failure.

-48V Cabinet Power Supply (VB-44022)

A -48V power supply must be installed in a cabinet when either DID, E&M and/or Ground Start Trunks are employed in the cabinet. The -48v power supply is "shelf-sensitive," meaning any cabinet which holds either DID, E&M, and/or Ground-Start trunk cards must have its own -48v power supply.

Battery Backup (VB-44025)

The backup batteries supply power to the system in the event of a power failure. If the Battery Backup option is chosen for the system, each cabinet requires its own set of batteries (1 kit per cabinet, 2 batteries per kit). The batteries can back up the system for up to 30 minutes.

Switch Box (VB-44023)

The Switch Box installs in the Base cabinet, and controls power for the Base cabinet and up to 2 Expansion cabinet(s) installed above it. When the power supply is turned on or off in the Base cabinet, power is also turned on or off for the Expansion cabinet(s).

Control Unit Processor Cards

Control Processor Card (96-port) - CPC-96 (VB-44410)

The CPC-96 supports a single cabinet (96 ports) and utilizes a 16-bit Central Processor Unit (CPU).

Included are the time switch functions (4 highway X 4 highway), 4 DTMF receivers, 8 pairs of conference circuits (3 Member), service tones, DTMF generators, an input terminal for external Music-On-Hold source (RCA jack), connecting terminals for network synchronous package, I/F connector for an external PC card, and a built-in emergency modem (300 bps).

Control Processor Card (288-port) - CPC-288 (VB-444201)

The CPC-288 supports up to three cabinets (288 ports) and utilizes a 16-bit CPU.

Included are 4 DTMF receivers, an input terminal for external Music-On-Hold source (RCA jack), I/F connector for an external PC card, and a built-in emergency modem (300bps).

The CPC-288 requires the TSW-288 Time Switch Card.

Control Processor Card (576-port) - CPC-576 (VB-444301)

This unit supports up to six cabinets (576 ports) and utilizes a 32-bit CPU.

It provides 4 DTMF receivers, an input terminal for external Music-On-Hold source (RCA jack), an I/F connector for a customized PCMCIA memory card, and a built-in emergency modem (300bps).

The CPC-576 requires the TSW-576 Time Switch Card.

Program downloads are performed to the internal memory of the system through the attached customized PCMCIA card. The PCMCIA card is necessary during normal operating time and cannot be removed during normal operation.

CPC Card Processor Unit Specifications		CPC-96 (VB-44410)	CPC-288 (VB-444201)	CPC-576 (VB-444301)
MPU (Main Processor Unit)				
CPU Used		68000 (16-bit)	68000 (16-bit)	68020 (32-bit)
Operating Clock		12.288 MHz	19.6608 MHz	20.000 MHz
Memory	Program Area (ROM):	FLASH: 4MB Boot ROM: 128kB	FLASH: 4MB Boot ROM: 128kB	6MB, including 128kB boot ROM (implemented as Simms)
	Work Area (DRAM):	2MB	2MB	6MB (implemented as Simms)
	Backup Area (SRAM):	2MB	2MB	3MB
Tone/PAD/CNF ROM		128kB	n/a	n/a
FPU (Function Processor Unit, for controlling Expansion cabinets)				
CPU Used		n/a	68000 (16-bit)	68000 (16-bit)
Operating Clock		n/a	12.288 MHz	12.288 MHz
Memory	Program Area (ROM):	n/a	128kB	128kB
	Work Area (DP-RAM):	n/a	32kB	32kB
	Backup Area (SRAM):	n/a	64kB	64kB

Time Switch Card - TSW-288 (VB-444202)

The TSW-288 provides the time switch circuitry required for up to 288 ports. This card must be used with the CPC-288. This unit installs in the first option slot of the first Base cabinet. Only one card can be installed in a system.

The TSW-288 provides the time switch (14 highway X 14 highway), service tones, DTMF generator, connecting terminals for network synchronizing unit interface, and eight 3-party conference circuits.

Time Switch Card - TSW-576 (VB-444302)

The TSW-576 provides the time switch circuitry required for up to 576 ports. This card must be used with the CPC-576. This card installs in the first option slot of the first Base cabinet. Only one card can be installed in a system.

The TSW-576 provides the time switch (24 highway X 24 highway), service tones, DTMF generator, connecting terminals for network synchronizing unit interface, and eight 3-party conference circuits.

Building Block Expansion Cable Kit - CBL (VB-44451)

This card supports the interconnection between DBS 576 cabinets in a multiple-cabinet system. This card establishes the bus connections (PCM highway and terminal control) of the Base cabinet and additional DBS 576 cabinets. It also controls the connection to the time switch unit (TSW-288/TSW-576) in the first Base cabinet.

Each cabinet after the first cabinet requires a CBL kit. The supplied card must be installed in the main processor slots of all but the first cabinet. The supplied inter-cabinet connection cable is used with each added cabinet.

DBS 576 to DBS Expansion Cable Kit - CBLDBS (VB-44452)

The CBLDBS card supports the interconnection between cabinets when DBS cabinets are connected to the DBS 576. This card establishes the bus connections (PCM highway and terminal control) between the base DBS 576 cabinet and the DBS cabinet(s). It also controls the connection to the time switch unit (TSW-288/TSW-576) installed in the first Base cabinet.

The CBLDBS card installs in the AUX1 slot of each connected DBS cabinet. An inter-cabinet connection cable is used with each cabinet.

NOTE: The DBS-576-to-DBS configuration can support a maximum of 528 ports, including the ports in the DBS cabinet. Up to 2 DBS cabinets can be included in the configuration.

DBS DEC (Digital Extension Cards) are supported, but there is no DBS TRK (trunk) card support. A special MDF board is required; it's included with the CBLDBS kit.

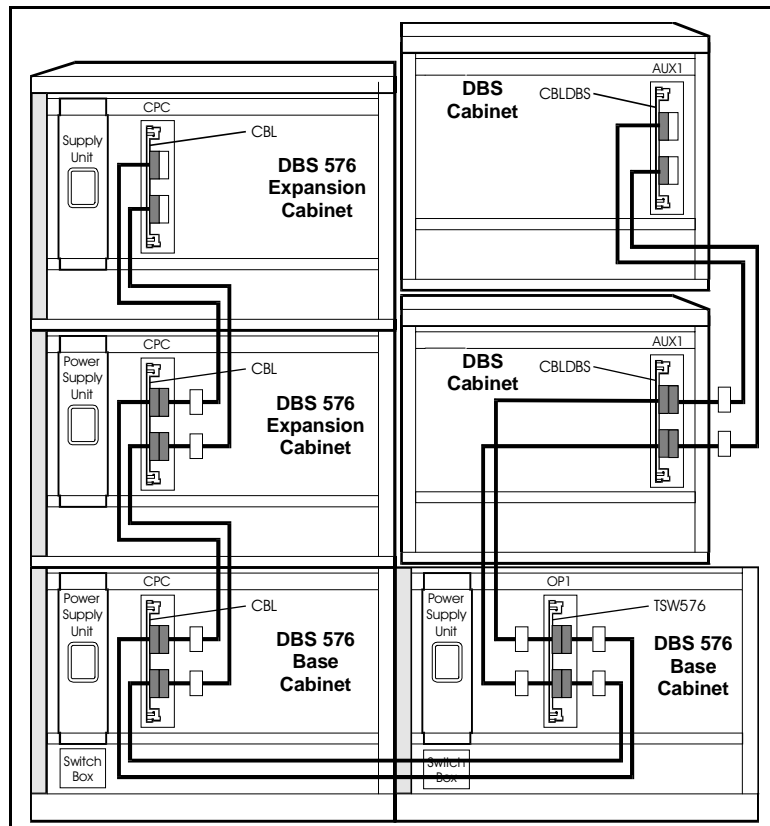

Network Synchronizing Unit - SYNC (VB-44460)

This unit provides network synchronization and is required with digital circuits such as ISDN and T1. The SYNC card synchronizes the PCM clock with an outside resource. When digital circuits are used, one SYNC card is required and installs on the CPC-96, TSW-288, or TSW-576 card.

Trunk/Tie Line Cards

Loop Start Trunk Card - LTRK/8 (VB-44510)

The Loop Start Card supports up to 8 loop start CO lines and can be installed in any flexible slot. This card meets UL1459 safety requirements, and can be directly connected to CO lines.

Loop Start/Ground Start Trunk Card - LGTRK/8 (VB-44511)

This card supports both Loop Start and Ground Start Trunks. Up to 8 CO lines of any combination of types can be connected. This card installs in any flexible slot. An internal -48V Power Supply (VB-44022) must be installed in the same cabinet with the Loop Start/Ground Start Card.

This card meets UL1459 safety requirements, and can be directly connected to CO lines.

Caller ID Unit - CID (VB-44513)

This card supports Caller ID on loop start trunks. This unit installs directly on top of the Loop Start Trunk Card (VB-44510), and supports all 8 of that Card's circuits for Caller ID.

ISDN Primary Rate Interface Card (T/S-point) - PRI/23 (VB-44540)

This supports T-point Integrated Services Digital Network (ISDN) Primary Rate Interface (PRI) (23B+D/24B:1544kbps) and also S-point ISDN PRI.

The PRI card can be set to support either 8, 16 or 23/24 channels. When the card is set for 16 channels, the card logically occupies 2 flexible card slots. When the card is set for 23/24 channels, the card logically occupies 3 flexible card slots.

Unlike most other cards, due to the interaction between card slots, the PRI card must be installed in specific Free Slots. Up to 3 PRI cards can be installed in a single cabinet. A fully configured 6-cabinet system can support up to 18 PRI cards.

T-point PRI requires a DSU (Digital Service Unit) for connection to the carrier circuit. A Network Sync card is also required.

ISDN Basic Rate Interface Card (T-point) - TBRI/4 (VB-44530)

This supports T-point Integrated Services Digital Network (ISDN) Basic Rate Interface (BRI) (2B+D:144kbps). This card can be installed in any flexible slot. Up to 4 T-point ISDN lines can be connected to each TBRI/4 Card.

The T-point BRI Unit supports information transferring capability (speech and data) at the CO trunk.

The TBRI/4 Card connects via NT1 (Network Termination Unit/Type 1) to the T-point ISDN interface.

E&M Trunk Card - E&M/4 (VB-44560)

This card supports E&M type tie line interface (Speech pass 4W/2W, Control line 4W). The signaling methods that are supported include Immediate and Wink methods. Each E&M card includes 4 circuits.

When installed in any flexible slot, the E&M Trunk Card supports call signal detection and answer from other PBX or carrier equipment, calling to the E&M tie line, dial sending and speech.

An internal –48V Power Supply (VB-44022) must be installed in the same cabinet with the E&M/4 Card.

The E&M interface can connect to another PBX with E&M capability (Types 1, 2 and 5 are supported).

External safety devices (available from standard telecommunications suppliers) are required when installing this unit outside the building.

DID Trunk Card - DIDTR/8 (VB-44520)

This card supports 8 DID incoming CO lines using Immediate and Wink signaling methods. The DID can be either Dial Pulse (10PPS) or DTMF (only for Wink). DTMF circuits are used when the Wink method is selected.

An internal –48V Power Supply (VB-44022) must be installed in the same cabinet with the DID Trunk Card.

T-1 Interface Card - T-1 (VB-44550)

The T-1 interface is a digital CO line card that provides up to 24 voice channels over a four-wire circuit.

The T-1 card can be set to support either 8, 16, or 24 channels. When the card is set for 16 channels, the card logically occupies 2 flexible card slots. When the card is set for 24 channels, the card logically occupies 3 flexible card slots.

Unlike most other cards, due to the interaction between card slots, the T-1 card must be installed in selected flexible card slots. Up to 3 T-1 cards can be installed in a single cabinet. A fully configured 6-cabinet system can support up to 18 T-1 cards.

The T-1 interface requires a DSU (Digital Service Unit) for connection to the carrier circuit. A Network Sync card is also required.

Trunk MDF Interface - MDF-CO (VB-44512)

The Trunk MDF interface card provides easy connection from the cabinet to the MDF via standard female 25-pair cables. This card supports Loop Start, Ground Start, and DID trunks. Since each of these trunk cards uses modular connectors, connection can be made directly to the modular connectors, bypassing the MDF if so desired.

Each Trunk MDF Interface Card can support up to three trunk cards (24 trunk circuits). Up to 10 Trunk MDF Interface Cards can be installed in each cabinet. MDF cards attach to the sides of the cabinet and are hidden by the housing for a neat appearance.

Extension Cards

Digital Extension Card - DEC/8 (VB-44610)

This card provides 8 digital circuits. Each circuit supports the Panasonic Digital Key Telephone, Digital Single Line Telephone, DSS/72, and EM/24. Supply voltage for the telephones is supplied by the digital circuits.

This card can be installed in any flexible slot.

Analog Extension Card - AEC/8 (VB-44520)

This card provides 8 analog circuits. Each circuit supports standard analog telephone devices such as analog telephones, answering machines, fax machines, modems, cordless telephones, etc. The connected device(s) can be either pulse dial (rotary) or DTMF. Ringer circuitry is built into the card.

ISDN Primary Rate Interface Card (T/S-point) - PRI/23 (VB-44540)

The PRI/23 card supports both S-point and T-point ISDN. See pg. 22 for more information.

ISDN Basic Rate Interface Card (S-point) - SBRI/4 (VB-44630)

This unit supports Basic Rate Interface (2B+D:144kbps) for S-point ISDN. Each card provides 4 BRI circuits.

This card can be installed in any flexible slot.

The S-point BRI Unit supports information transferring capability (speech and data) at the CO trunk.

Extension MDF Interface - MDF-EXT (VB-44611)

The Extension MDF Interface provides for connection from the cabinet to the MDF using standard 25-pair cables. A cable is run from the front of the extension card to the Extension MDF card. Each Extension MDF card can support any combination of up to 3 DEC/8 or AEC/8 extension cards. Up to 10 extension MDF interfaces can be installed in each cabinet.

Options

Service Circuit Card - SCC (VB-44181)

This card provides enhanced service functions such as two RS232C ports (9600bps), a Background Music input, and two-way external paging control.

Only one SCC can be installed in a DBS 576 phone system.

RS232C port:	2 ports (maximum 9600bps)
BGM input terminal:	1 port (with RCA jack)
On/Off control of external amplifier:	1 contact
On/Off control of external equipment:	5 contacts (withstand voltage 30V)
Maximum current of control board:	.25mA total
Paging Output - with Control Output:	maximum 2A (control output)

DTMF Multi-Frequency Receiver Card - MFR/8 (VB-44110)

The MFR/8 card accepts dialed DTMF tones and determines the dialed digits. Each card contains 8 receiver circuits.

This card can be installed in either an option slot or any flexible slot. The maximum number of MFR/8 cards that can be installed depends on the number of ports in the system: 1 MFR/8 card in a 96-port (1-cabinet) system; 2 MFR/8 cards in a 192-port (2-cabinet) system, ... 6 MFR/8 cards in a 576-port (6-cabinet system). However, all the MFR/8 cards can be placed in the same cabinet.

Power Failure Transfer Unit (VB-43703)

This 4-line unit is designed to switch outside dial tone from the telephone company direct to an SLT phone when power is lost. The Power Failure Transfer Unit connects 4 SLTs to 4 CO lines.

Conference Card (4 circuits) - CONF (VB-44120)

This is a conference speech card with four 8-party conference circuits. One conference card per cabinet can be installed into any flexible slot (if only one circuit is used), or into flexible slot 1, 5, or 9 (if more than one circuit is used). An 8-party conference can consist of 8 extensions; 7 extensions + 1 external line; or 1 extension + 7 external lines (or any combination in between).

Application Processor Interface Card - API (VB-44131)

The API provides an interface path between the telephone system's information BUS and a personal computer-based application (such as external integrated voice mail or external enhanced ACD).

External interface: RS232C port (19200bps maximum)

Built-In ACD Card - ACD (VB-44140)

This card, combined with the Voice Processor Unit card (4 circuits) (VB-44160), provides basic Automatic Call Distribution functions. MIS (Management Information System) reports can be output from the RS232C port of the ACD card. The reports can be printed out by connecting a printer to the RS232C port. However, a PC and printer cannot be simultaneously connected to the RS232C (the RS232C cable must be used exclusively for one connection).

Only one Built-In ACD can be installed in a cabinet. A maximum of two Built-In ACDs can be installed in a system.

Built-In Voice Mail and Built-In ACD cannot be installed in the same cabinet, since they use the same flexible slots.

Built-In Voice Storage Card - VSSC (VB-44170)

This is one of two cards required for Built-In Voice Mail (the Voice Processing Card is also required - see below).

The Voice Storage Card provides most of the functions of Built-In Voice Mail, including hard disk storage of the voice data.

Only 1 Built-In Voice Mail Unit can be installed in a single cabinet. A maximum of 4 Built-In Voice Mails can be installed in a multiple-cabinet (4 or more cabinets) system.

Built-In Voice Mail and Built-In ACD cannot be installed in the same cabinet, since they use the same flexible slots.

Voice Processing Card (4 circuits) - VPU/4 (VB-44160)

This card contains 4 voice processing circuits. It can be used with Built-In Voice Mail and Built-In ACD. (There is another Voice Processing Card, VB-44150, that contains 8 voice processing circuits and can be used only with Built-In Voice Mail.)

Built-In Voice Mail requires 1 or 2 voice processing cards; any combination of the two types is acceptable. Built-In ACD uses only 1 voice processing card (the 4-circuit card).

Voice Processing Card (8 circuits) - VPU/8 (VB-44150)

This card contains 8 voice processing circuits. It can be used only with Built-In Voice Mail, either alone or in a 2-card combination of voice processing card types (4-circuit or 8-circuit).

Station Equipment

Overview

The full line of Panasonic DBS phone systems offer a wide variety of critically acclaimed telephones. All models except for the DSLT are available in two colors: pearl gray and black. (The DSLT comes in pearl gray only.)

As the user interface, the station instrument is a crucial element of the communications system. All DBS telephones are designed to provide easy access to system features and functions. A mixture of fixed and programmable feature keys allow the station to be specifically customized to accommodate the needs of each user. A wide variety of telephones are offered with different combinations of programmable keys, speakerphones, and liquid crystal displays to provide a complete solution to any telecommunication requirement. The advanced economic design and quality manufacturing assure longevity of the DBS system and stations, protecting the investment of the end-user.

All telephones are designed with the following features:

- A 1" LED Message-Waiting lamp for voicemail/internal message alert.
- Dual-color LEDs for status indication.
- Off-Hook Voice Announce circuitry.
- Off-Hook Monitoring circuitry that allows additional listeners the opportunity to hear phone conversations through the speaker.
- Key lettering is a part of the key mold, making it impossible for lettering to fade or rub off.
- Special film coating enables displays to be seen under extremely bright lighting conditions.
- Adjustable display contrast levels adapt to different lighting conditions.
- Adjustable base for 3 different LCD viewing positions (VB-44 series only).
- Photo coupled controlled hookswitch, which extends the life of the hookswitch.
- Unique one-board design that allows for a more compact, durable product.
- Special material separating the keys from the PCB reduces damage from liquid spills.
- Built-in processors provide automatic identification when plugged in at any digital port, assuring instant operation.
- Above-standard cords contain clamps to attach to the telephone's base, alleviating stress on modular connectors.
- Volume controls of dB levels can be automatically and/or manually adjusted.
- Hearing-aid compatible.
- Headset compatible.
- Built-in wall mounting capability in the base of the telephone.
- Textured finish on selected high-contact areas reduces scratching and fingerprints.
- Molded with an extremely durable, high-impact polymaterial for break resistance.
- Telephone handsets allow easy installation of handset cord swivels.

Model Options

Panasonic offers a wide variety of options for telephones so that you can select the one that is just right for you. All phones are digital, and all except for the DSLT have a microphone and speaker for Hands-Free Answerback and Off-Hook Monitoring (the ability to conduct calls on-speaker without lifting the handset). All display phones are “speakerphones,” meaning they have additional built-in circuitry for background-noise cancellation during outside calls. The Small-Display phones have a 2-line LCD; the Large-Display phone has a 7-line LCD.

Also available on all phones except DSLTs are Flexible Function (FF) keys, which have dual-colored LEDs and can be programmed by end-users to access outside lines or execute system and station features. And the EM/24 and DSS/72 units offer additional panels of FF-keys that you can add-on to any digital station.

The following table shows some of the options available with the different models.

Station Telephone Models

Description	No. of FF-Keys	HFAB-ICM	Speaker phone	Display	Gray	Black
Digital Single Line Telephone (DSLTL)	0				✓	
16-Key Standard Phone	6	✓			✓	✓
22-Key Standard Phone	12	✓			✓	✓
22-Key Small-Display Phone	12	✓	✓	✓	✓	✓
22-Key Small-Display Phone with Voice Response	12	✓	✓	✓	✓	✓
22-Key Large-Display Phone	12	✓	✓	✓	✓	✓
34-Key Standard Phone	24	✓			✓	✓
34-Key Small-Display Phone	24	✓	✓	✓	✓	✓
24-Key Expansion Module (EM/24)	24				✓	✓
72-Key DSS/BLF Module (DSS/72)	72				✓	✓

Model Descriptions

Digital Single Line Telephone (DSLTL) Gray only (VB-41200)

Provides single-line service on a digital telephone. Buttons include hold, on/off, auto, redial, flash and conference. Large message-waiting light. Slide controls for volume adjustment. Does not support hands-free answerback on intercom. Requires one digital port. Does not include user tray.

16-Key Standard Phone Gray (VB-44210G) Black (VB-44210B)

Provides 6 flexible feature/line keys (dual colored LED) and 10 personal speed dial keys. Supports hands-free answerback on intercom, offhook voice announce, and headsets. Requires one digital port. Wall-mountable. Includes user tray and elevation supports.

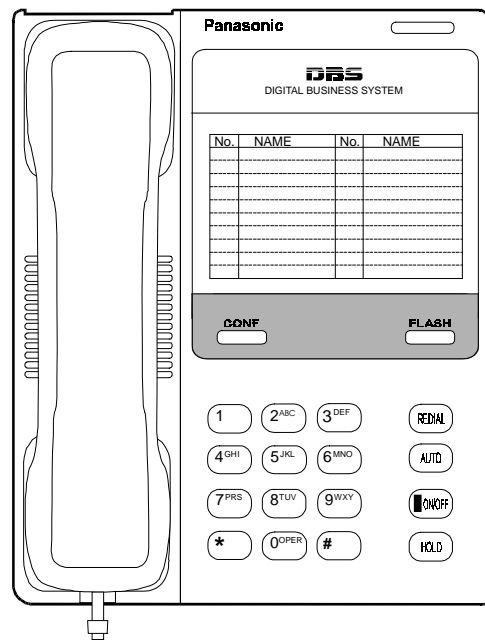

The DSLTL (VB-41200)

22-Key Standard Phone

Gray (VB-44220G)

Black (VB-44220B)

Provides 12 flexible feature/line keys (dual colored LED) and 10 personal speed dial keys. Supports hands-free answerback on intercom, offhook voice announce, and headsets. Requires one digital port. Wall-mountable. Includes user tray and elevation supports.

22-Key Small-Display Phone

Gray (VB-44223G)

Black (VB-44223B)

Provides 12 flexible feature/line keys (dual colored LED) and 10 personal speed dial keys with an integrated hands-free speakerphone and a 2-line liquid crystal display (LCD). 4 programmable softkeys are included with the display to provide access to advanced system features. Supports hands-free answerback on intercom, offhook voice announce, and headsets. Requires one digital port. Wall-mountable. Includes user tray and elevation supports.

22-Key Small-Display Phone with Voice Response

Gray (VB-44224G)

Black (VB-44224B)

Provides 12 flexible feature/line keys (dual colored LED) and 10 personal speed dial keys, with an integrated hands-free speakerphone and a 2-line liquid crystal display (LCD). 4 programmable softkeys are included with the display to provide access to advanced system features. Supports hands-free answerback on intercom, offhook voice announce, and headsets. Requires one digital port. Wall-mountable. Includes user tray and elevation supports. Internal circuitry for Voice Recognition feature.

22-Key Large-Display Phone

Gray (VB-44225G)

Black (VB-44225B)

Provides 12 flexible feature/line keys (dual colored LED) with a 7-line Liquid Crystal interactive display. The top line of the display contains 15 characters. The remaining 6 lines contain 16 characters each. There are 10 softkeys to interact with the large screen display. User-definable screens provide ultimate user-friendly flexibility. This telephone comes equipped with a built-in speakerphone for hands-free conversation on outside line calls, and a hands-free answerback circuit for responding to intercom calls. This telephone also supports offhook voice announce and headsets. Requires one digital port. Wall-mountable. Includes user tray and elevation supports.

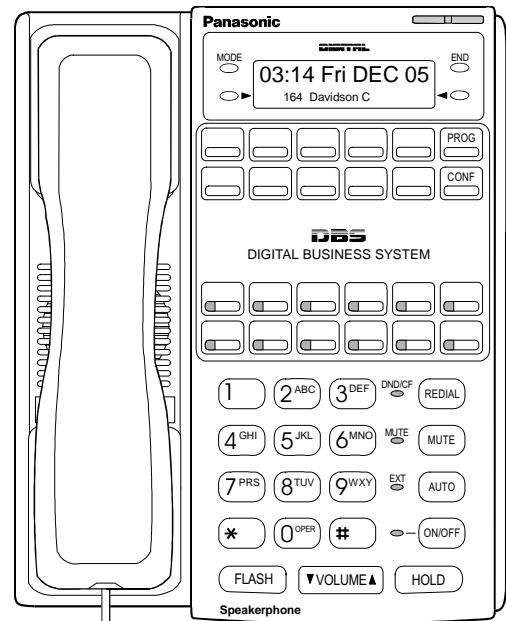

**The 22-Key Small-Display Phone
(VB-44223_)**
with Voice Response (VB-44224_)

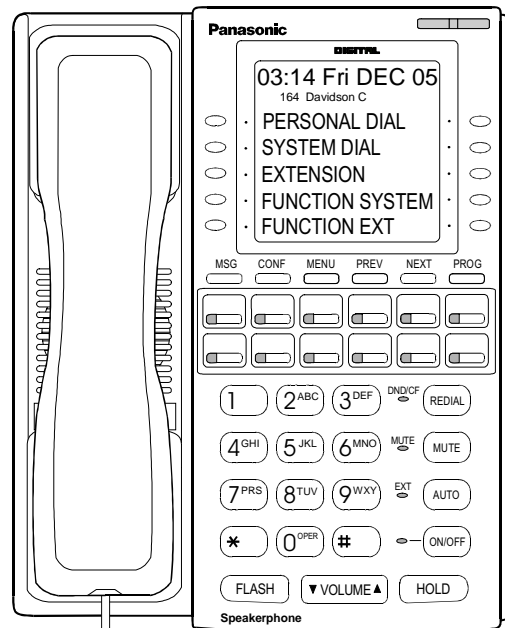

**The 22-Key Large-Display Phone
(VB-44225_)**

34-Key Standard Phone

Gray (VB-44230G)

Black (VB-44230B)

Provides 24 flexible feature/line keys (dual colored LED) and 10 personal speed dial keys. Supports hands-free answerback on intercom, offhook voice announce, and headsets. Requires one digital port. Wall-mountable. Includes user tray and elevation supports.

34-Key Small-Display Phone

Gray (VB-44233G)

Black (VB-44233B)

Provides 24 flexible feature/line keys (dual colored LED) and 10 personal speed dial keys, with an integrated hands-free speakerphone and a 2-line liquid crystal display (LCD). 4 programmable softkeys are included with the display to provide access to advanced system features. Supports hands-free answerback on intercom, offhook voice announce, and headsets. Requires one digital port. Wall-mountable. Includes user tray and elevation supports.

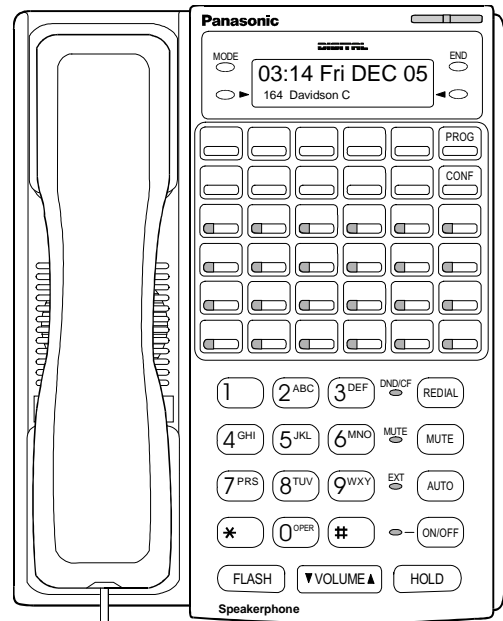

The 34-Key Small-Display Phone (VB-44233_)

24-Key Expansion Module (EM/24)

Gray (VB-44310G)

Black (VB-44310B)

Provides 24 flexible feature/line/DSS/BLF keys (dual colored LED). This unit is used in conjunction with a digital station. Comes equipped with a joining bracket to connect it to the telephone to give the appearance of one complete unit. Requires its own digital port. Wall-mountable. Includes elevation supports.

72-Key Direct Station Select/Busy Lamp Field Module (DSS/72)

Gray (VB-44320G)

Black (VB-44320B)

Provides 72 flexible feature/line/DSS/BLF keys (dual colored LED). Normally used in conjunction with attendant console positions, but can be used with any digital station. Comes equipped with a joining bracket to connect it to the attendant telephone to give the appearance of one complete unit. Up to 5 DSS/72s can be joined to a single phone. Each DSS/72 requires its own digital port. Wall-mountable. Includes elevation supports.

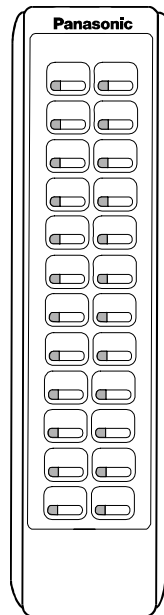

The EM/24 (VB-44310_)

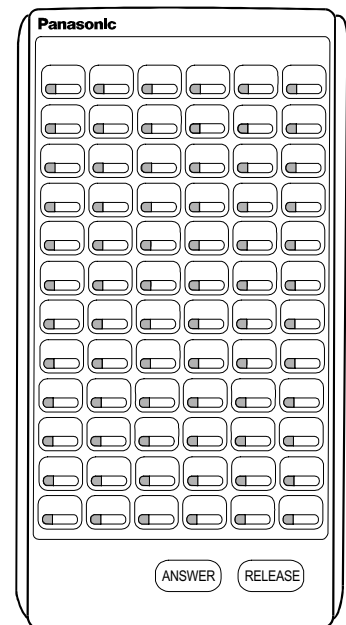

The DSS/72 (VB-44320_)

Optional Terminal Devices

Voice Recognition Unit Adapter (VB-44101)

Working in conjunction with the 22 Button Display Telephone (VB-44224G/B), this adapter adds voice response functions to the telephone. The user can program the telephone to automatically dial numbers based on the user's voice commands.

PC Phone (VB-44332)

The PC Phone is designed to replace an extension phone, adding telephony capability to a desktop PC. It is comprised of a PC card installed inside the computer; application software; and various connections to the computer (e.g., handset, headset, etc.). The PC Phone then plugs into a DBS 576 extension port, and becomes a sophisticated "on-screen" phone for the end-user. For more information, see *Chapter 5 - Special Applications*.

PC Attendant Console/96 (VB-44330)

This is one of two PC Attendant Consoles offered by Panasonic; both consoles are designed to replace an Attendant phone and add telephony capability to a desktop PC. The PC Attendant Console/96 is a 2-port solution that is equivalent to one key phone (either a 34-key small-display phone, or a 22-key large-display phone) with one DSS/72; it can monitor up to 96 extension ports. For more information, see *Chapter 5 - Special Applications*.

PC Attendant Console/384 (VB-44331)

This is one of two PC Attendant Consoles offered by Panasonic; both consoles are designed to replace an Attendant phone and add telephony capability to a desktop PC. The PC Attendant Console/384 is a 6-port solution that is equivalent to one key phone (either a 34-key small-display phone, or a 22-key large-display phone) with five DSS/72 consoles; it can monitor up to 384 extension ports. For more information, see *Chapter 5 - Special Applications*.

Telephone Key Layout

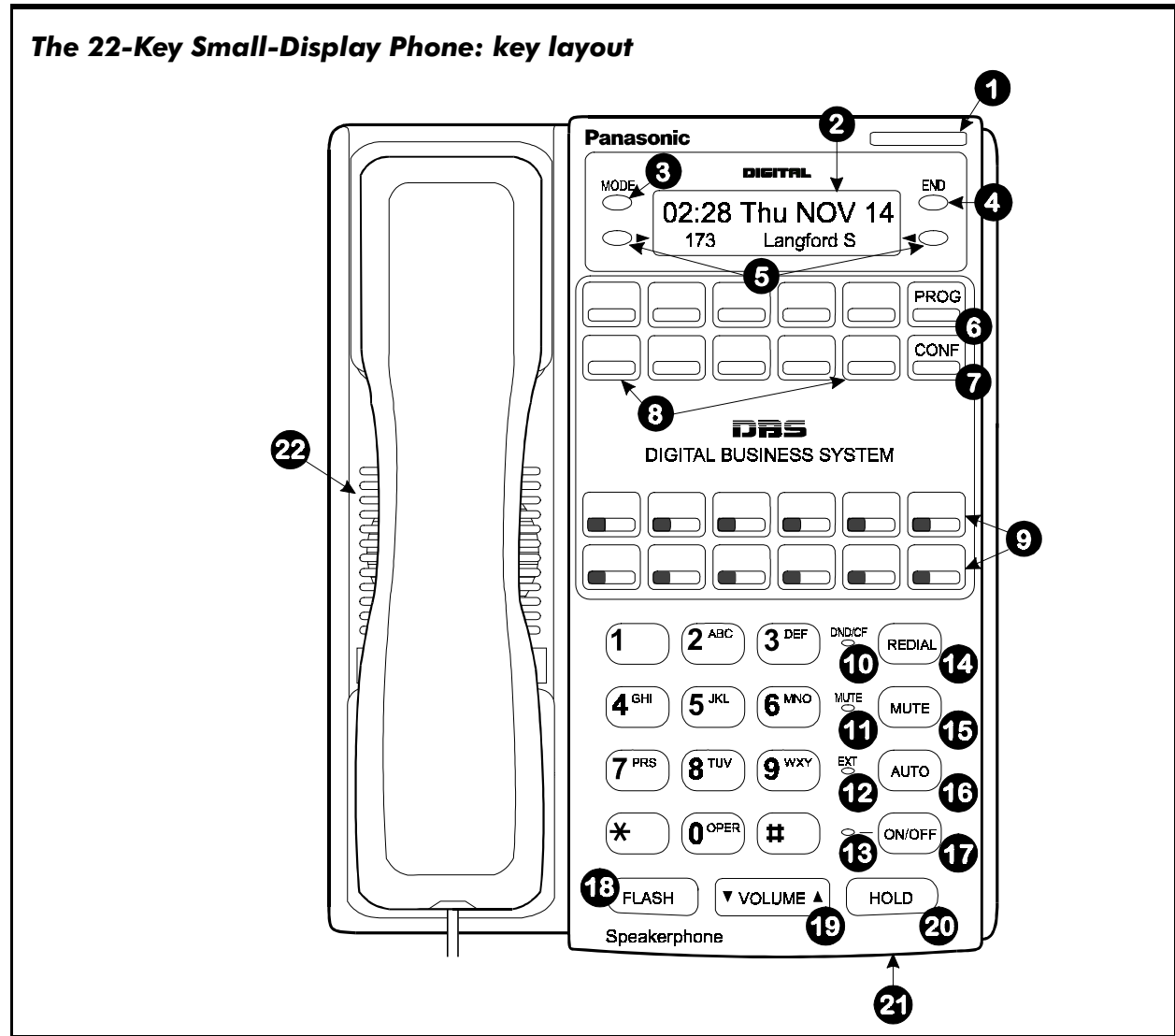

Small-Display Phone Features

No.	Feature	Description
1	Message Waiting Indicator	Indicates that you have a message.
2	Display	Displays information about the phone's status, menus, and dialing directories.
3	MODE Key	Used to change display modes from Default Mode to Speed Dial Mode or Extension Directory Mode.
4	END Key	Used to exit Directory Mode and return the display to Default Mode.
5	Soft Keys	Used to select speed dial directories, Caller ID numbers, or extension numbers.

No.	Feature	Description
6	PROG Key	Used to program Flexible Function (FF) and one-touch keys, to adjust ringer volume, and to send a flash signal. Depending on the setup of your system, may also be used to transfer calls.
7	CONF Key	Used to establish conference calls and to check FF key and one-touch features.
8	One-Touch Keys	Used to make outside calls or to access system features.
9	Flexible Function (FF) Keys	Used to access outside lines or to access system features.
10	DND/CF Indicator	Indicates that Do-Not-Disturb (DND) or Call Forwarding is set.
11	MUTE Indicator	Indicates that your voice is muted (i.e., party on the other end cannot hear you). Lights solid when your hands-free microphone is muted and flashes when your handset is muted.
12	EXT Indicator	Lights when you are on a call and flashes when you hold a call.
13	ON/OFF Indicator	Lights when the ON/OFF key has been pressed.
14	REDIAL Key	Used to redial the last number dialed.
15	MUTE Key	Used to activate/deactivate the Mute function. When activated, the party on the other end cannot hear you. (See item 11, MUTE Indicator.)
16	AUTO Key	Used to access speed dialing or enter account codes.
17	ON/OFF Key	Used to make a call without lifting the handset or to turn the speaker on and off.
18	FLASH Key	Used to end an outside call and to either restore outside dial tone or switch to external dial tone status without hanging up the receiver.
19	VOLUME Key	Used to adjust the level of tones, background music, ringing, receiver volume, and display contrast.
20	HOLD Key	Used to hold calls, to retrieve held calls, and to complete FF key programming.
21	Microphone	Used to talk to another party without using the handset.
22	Speaker	Outputs tones and voice at your extension.

No.	Feature	Description
6	MENU Key	Used to return to the default Main Menu screen which contains the following items: <ul style="list-style-type: none"> • Personal Dial • System Dial • Extension • Function System • Function Ext
7	PREV Key	Used to return to the previous screen.
8	NEXT Key	Used to advance to the next screen.
9	PROG Key	Used to program FF and one-touch keys, to adjust ringer volume and to send a flash signal. Depending on the setup of your system, may also be used to transfer calls.
10	Flexible Function (FF) Keys	Used to access outside lines or to access system features.
11	DND/CF Indicator	Indicates that Do-Not-Disturb (DND) or Call Forwarding is set.
12	MUTE Indicator	Indicates that your voice is muted (i.e., party on the other end cannot hear you). Lights solid when your hands-free microphone is muted and flashes when your handset is muted.
13	EXT Indicator	Lights when you are on a call and flashes when you hold a call.
14	ON/OFF Indicator	Lights when the ON/OFF key has been pressed.
15	REDIAL Key	Used to redial the last number dialed.
16	MUTE Key	Used to activate/deactivate the Mute function. When activated, the party on the other end cannot hear you. (See item 12, MUTE Indicator.)
17	AUTO Key	Used to access speed dialing or enter account codes.
18	ON/OFF Key	Used to make a call without lifting the handset or to turn the speaker on and off.
19	FLASH Key	Used to end an outside call and to either restore outside dial tone or switch to external dial tone status without hanging up the receiver.
20	VOLUME Key	Used to adjust level of tones, background music, ringing, receiver volume, and display contrast.
21	HOLD Key	Used to hold calls, to retrieve held calls, and to complete FF key programming.
22	Microphone	Used to talk to another party without using the handset.
23	Speaker	Outputs tones and voice at your extension.

Chapter 3 - System Features

Overview

This chapter describes some of the most powerful, technologically advanced features inherent in the DBS 576 that are available system-wide. The first part of this chapter highlights the most popular features in alphabetical order. Following these highlights is a complete list of system features and the DBS 576 versions to which they apply.

Popular System Features

AEC DISCONNECT

Description:

Analog station ports can generate a positive disconnect (open loop) to devices that are attached to it upon hang-up.

Benefits:

- Allows quick disconnection from third-party voicemail or similar devices.

ATTENDANT GROUPS

Description:

Many systems are designed with multiple answering positions to handle the various call traffic which exists within an organization. With this in mind, the DBS 576 was designed to allow attendant groups to be set up to handle these calls. When "0" is dialed, the system will hunt through a pre-established list of extensions to make sure the call is answered.

Benefits:

- Relief for attendants is automatically built-in.
- All calls will be answered.

Applications:

- Any organization that handles many calls throughout the working period

AUTO DAY/NIGHT MODE

Description:

The DBS 576 system provides three different modes of operation. We call them Day 1, Day 2 and Night mode. Each of these modes can have a different Attendant as well as different ringing position assignments for extensions. The system can be programmed to automatically switch in and out of any one of these modes at a preset time each day. Weekends, holidays, and other special days can also be programmed with their own separate modes.

Benefits:

- Enables the system's ringing and dialing capabilities to change automatically when the mode is switched.

Applications:

- Lines that need to be switched over to an answering machine or voicemail system after-hours
- Lines that require toll restrictions after-hours so unauthorized personnel cannot dial long distance
- Different mode for lunchtime operation

AUTOMATIC ROUTE SELECTION (ARS)

This feature enables the system to select the most appropriate route for an outgoing call (i.e., the least expensive one). Working in conjunction with Toll Restriction Service (TRS), the call can also be denied based on the TRS level for the station (or user) placing the call.

There are three levels of ARS, based on the number dialed after the ARS access code:

- **Direct Route Selection.** The simplest form of ARS routing. Directly selects the trunk group and (if programmed) modifies the dialed number by deleting some of the first digits dialed, and/or adding digits to the beginning or end of the dialed number.
- **Route List Selection.** A more complex routing method that includes up to 5 alternative levels of route selection.
- **Time List Selection.** The most complex routing method that determines the appropriate route list based on the day and time.

For “exceptions to the rule” such as holidays, up to 20 Special Days can be defined in programming with their own separate ARS routing methods.

Codes can be defined in ARS programming for automatic adding to (or deleting from) the beginning or end of a dialed phone number (the user won't even know these Codes are being dialed). For example, these Codes can insert a pause, or switch signaling to DTMF, or just tack on additional digits that are needed by the CO.

Forced ARS (where the user must dial an ARS access code to be able to dial-out) can be enabled/disabled via the Extension COS assignment.

Benefits:

- Lets the customer (management) control the routing of outgoing calls by defining the route to be selected.
- Provides an effective means of cost control for expensive long-distance calls.
- Provides greater security, as end-users don't need to know the Itemized Codes or Authorization Codes used to place calls to the CO.

CALL TRAFFIC REPORTING

Description:

Traffic data can be stored and printed for intercom calls, incoming trunk calls, and outgoing trunk calls.

Benefits:

- Information can be used to evaluate CO line usage and control costs.

CALLER ID

Description:

Caller Identification (CID) is an optional service offered by your local telephone company which adds the following functions to a display phone:

- LCD indication of caller information.** Users can see caller information (both name and number) displayed while the incoming call is ringing their extension. This includes ISDN digital messaging through the D-channel, also known as ANI (Automatic Number Identification).
- Log of caller information.** The Call Log keeps a record of the last 10 CID calls received at an individual phone, and allows the user to view the Log and select from it to place a call. Up to 20 phones per cabinet can have the Call Log feature.
- SMDR recording.** CID information can be sent to the RS232C serial port so that it can be printed to a serial printer or call accounting system.
- CID notice to CTI.** CID information sent by the CO can be output to TAPI and other CTI devices.

Benefits:

- Allows users to handle calls more efficiently by knowing who is calling before they answer.
- Enables users to return calls that ring unanswered at their phones.

CLASS OF SERVICE (COS) RESTRICTION

Description:

Specific feature restrictions can be placed on extensions or on trunks. There are up to 16 definable classes of service for extensions, and 16 more for trunks. If no COS is assigned, most features are allowed.

Benefits:

- Allows users to have telephones customized to their needs.

Applications:

- Users with Single Line Telephones (SLTs) or those who need to limit access to various features on selected telephones

CONFERENCING

Description:

Any digital phone user can initiate a conference that includes from 2 to 7 other participants, who can be either intercom phone users or outside parties. (NOTE: Optional equipment must be installed in the DBS 576 cabinet to support more than 3 parties in a conference.) During a 3-party conference, a digital intercom phone participant can establish a private conversation with one of the other parties, then rejoin both to the conference. Since the system is digital, there is no internal dB loss during a conference - but you can still program additional dB gain/loss settings for conference calls.

Benefits:

- Saves time and money associated with conferencing geographically-separated employees, customers, etc.
- Users can establish their own conference calls without auxiliary equipment.

CTI (COMPUTER TELEPHONY INTEGRATION)

Description:

For desktop computer-driven applications on a station-to-station basis, the Panasonic DBS 576 supports Microsoft's Windows-based Telephone Application Programming Interface (TAPI). The

system also offers powerful computer/phone integrations for the Attendant position (via our **PC Attendant Console**) as well as end-user phones (via our **PC Phone**). For more information about these CTI applications, see *Chapter 5 - Special Applications* in this document.

Benefits:

- Enables customers to operate more efficiently by taking advantage of the latest telephone and computer convergence. These industries are coming together to offer a more intelligent and streamlined way to do business.

Applications:

- Control and pull up information on your “on-screen” phone based on caller information
- Allows computer applications to control telephone operation

DATA SECURITY

Description:

Data Security makes it possible to prevent interruptions on a phone. This feature is often used when the phone is hooked up to a modem, but it could also be used for confidential or sensitive calls. Data Security can be implemented for all phone usage, or it can apply only to outside line use.

Benefits:

- Ensures confidentiality on important calls.
- Protects data transmissions from being interrupted or cut off.

Applications:

- Modem phones
- Sensitive accounts (i.e., lawyers, doctors, etc.) where confidentiality is important

DELAYED RINGING

Description:

An incoming or transferred call as well as intercom calls can be programmed to ring at a secondary answering position if the call rings the primary answering position more than a specified length of time. The call can be programmed to ring at one or more delay ringing positions (including phones with BLF keys). This feature also works with Direct Inward Dialing (DID) calls.

Benefits:

- Ensures that a call does not go unanswered or ring for an extended period of time.

Applications:

- Any company that experiences short, temporary periods of high traffic and needs to ensure that calls are answered
- Backup support functions to cover void periods of the workday.

DISA (DIRECT INWARD SYSTEM ACCESS)

Description:

Any number of CO lines can be assigned to DISA lines which after being accessed, will enable the incoming caller to dial any extension within the system. Or, if the proper security code is entered, the caller will be able to access outside lines. Remote programming can also be done over these lines after entering a password.

Benefits:

- Allows internal personnel to access the system without tying up the attendant or other lines coming into the system.
- Enables people away from the office to access T1, FX (Foreign Exchange), Network, etc., to make long-distance calls using less expensive means.

Applications:

- Field sales people, repeat customers, etc.

DISTINCTIVE RINGING

Description:

Individual CO lines and stations can have their own unique ring pattern and frequency for incoming calls, to distinguish them from other lines or phones. If no distinctive ringing is assigned, the CO's ring pattern will be heard.

Benefits:

- Allows users to recognize the ring of their own individual telephones, or distinguish between different types of incoming calls.

Applications:

- Companies with separate departments or large, open bullpen areas

FLEXIBLE DIAL PLAN

Description:

The DBS 576's dial plan is flexible. This means that the system comes with a default set of feature codes, which can be changed. (For example, the default Call Forward-All Calls feature code is 721. But you can change it to 7, or 2#, or ***, or anything else between 1 and 4 digits long.)

It also means that you can have two different sets of feature codes for each system, dividing extensions into two different groups (for example, SLT phones can have a different set of feature codes than digital extensions). Each extension can be assigned Dial Plan #1 or Dial Plan #2.

Benefits:

- Analog and digital phones can each have a unique set of feature codes.
- The 576 can be designed to match the current phone system's feature numbering plan, therefore minimizing training.

FLEXIBLE RINGING ASSIGNMENT

Description:

Ring assignment is completely flexible so any CO line can be assigned to ring at any station with a line-appearance key. This ringing assignment can differ in Day 1, Day 2, and Night modes depending on user requirements.

Benefits:

- Assures coverage for outside lines, increasing customer satisfaction.
- Allows for customization of the system in order to meet a wide variety of applications.

Applications:

- Any organization that is separated from main answering position
- Departments that continue operations after receptionist switches system into Night mode can continue to make and receive calls

“HOWLER” TONE

Description:

If any phone is unintentionally left off-hook, the phone will emit a “howler” tone so someone nearby will notice and hang it up. This feature can be enabled/disabled system-wide, and the timer for it is also programmable.

Benefits:

- Helps keep phones or trunk lines from being inadvertently tied up because someone didn't put the handset back in the cradle.

HUNT GROUPS

Description:

Calls can be automatically transferred to hunt groups, which consist of member positions #1 thru #20 to which extensions can be assigned (for example, Extension 201 is Member #1, Extension 314 is Member #2, Extension 268 is Member #3, ... Extension 107 is Member #20). For each hunt group, you can choose one of four different automatic hunting methods in programming:

- Pilot Terminal hunting.** When a call is directed to the pilot number of the hunt group, Member #1 is tried first. Hunting proceeds forward through the sequential members to the end of the hunt group. If Member #20 (last member) doesn't answer, the call then returns to Member #1 again, and the hunt cycle is repeated until a member answers the call.
- Pilot Distributed hunting.** When a call is directed to the pilot number of the hunt group, the next sequential member after the member who received the last call, is tried first. Hunting then proceeds forward from that member, through the sequential members to the end of the hunt group. If Member #20 (last member) doesn't answer, the call then goes to Member #1, and hunting proceeds forward through the hunt group again. The hunting cycle (Member #1 thru Member #20) repeats until a member answers the call.
- Circular hunting.** This is for direct calls to member extensions (no pilot number involved). Starting at the member extension receiving the call, hunting proceeds forward through the sequential members to the end of the hunt group. If Member #20 (last member) doesn't answer, the call then goes to Member #1, and hunting proceeds forward through the hunt group again. The hunting cycle (Member #1 thru Member #20) repeats until a member answers the call.
- Switchback hunting.** This is also for direct calls to member extensions (no pilot number involved). Starting at the member extension receiving the call, hunting proceeds forward through the sequential members to the end of the hunt group. It then returns to the receiving (originally called) member, and hunts backward through the members to the beginning of the hunt group. Then it returns to the receiving member again, and hunts forward. This return-forward/return-backward hunt cycle repeats until a member answers the call.

The number of hunt groups available depends on how many cabinets you specify in programming (12 hunt groups per cabinet). Each hunt group can have its own unique characteristics such as hunting method, no-answer timeout/destination, etc. In other words, via programming you can control how long a Member will ring before the call moves to the next Member, and also how long before (or whether) the call will be transferred out of the Hunt Group to an extension or to another Hunt Group.

Benefits:

- Allows calls to be distributed among a group of extensions where a group of people answer the same calls.
- Voicemail systems use hunt groups to distribute calls.

Applications:

- Customer service departments, sales & marketing divisions, technical support groups, etc.

MULTIPLE DIRECT INWARD DIAL (DID) ASSIGNMENT

Description:

This feature allows a DID number to ring on more than one telephone through the use of virtual ports. Also, one telephone can have multiple DID numbers assigned to it.

Benefits:

- Improves coverage of DID numbers and allows more flexibility in how an end-user can program the numbers.

Applications:

- Executive suites, travel agencies, answering services

RECALL TIMERS

Description:

The DBS 576 is equipped with various system-wide and station-specific recall timers that help direct unanswered (maybe forgotten) calls to someone who can answer them:

- Start Recall from Hold or Park** - how long a call will remain on hold before recalling (ringing at) the extension, SLT, or Attendant that put it on hold or park hold. Each of these destination types has its own separate recall timer in the system. Also, individual groups of stations can be programmed to recall more quickly/slowly from their own calls on hold.
- Start Recall from Transfer** - the maximum amount of time a transferred call will ring unanswered before it goes back to (starts ringing at) the phone that made the transfer. Attendants have their own Transfer Recall Timer, separate from extensions and SLTs. Also, individual groups of stations can have a quicker/slower timer for their own unanswered transfers.
- Recall Duration** - how long a recall will ring before reverting to the default phone position (usually the Attendant Group).
- Reversion Duration** - how long a reverted call rings the Attendant Group before being disconnected (this can be set to “ring indefinitely”).

Benefits:

- Improves call handling efficiency and ensures that held/transferred calls will not be lost or forgotten.

SLIDE RINGING

Description:

This is a type of delayed ringing for CO line FF-keys. You can program a CO line to ring incoming calls on certain phones first, then (if they remain unanswered) have them start ringing on other phones that have an FF-key appearance for that line. You can enable/disable this feature on individual extensions and individual trunks. You can also set a timer for determining when Slide Ringing begins on the FF-keys.

Benefits:

- Provides delayed ringing for multiple line-appearance calls.

STATION MESSAGE DETAIL RECORDING (SMDR)

Description:

By attaching a serial printer to the RS232C port, a detailed record of all incoming and outgoing calls, can be kept for future reference.

Through programming, the titles for each page can be removed to allow for connection to call accounting services.

The following is an explanation concerning the output format and display contents for call data:

SMDR Output Data Format

Format #1
I MM/DD HH:MM:SS HH:MM:SS NNNN TTTT ddddddddddddddddddddddd aaaaaaaaaa vvvH
 ① ② ③ ④ ⑤ ⑥ ⑦ ⑧ ⑫

Format #2
I MM/DD HH:MM:SS HH:MM:SS NNNN TTTT ddddddddddddddddddddddd aaaaaaaaaa vvv
 ① ② ③ ④ ⑤ ⑥ ⑦ ⑧

dddddddddddddddddd cccccccc MM:SSH
 ⑨ ⑩ ⑪ ⑫

① Condition Code:

INCOMING CALLS:		OUTGOING CALLS:	
I	Incoming Call	F	Call Forward Outside
D	DID Incoming Call	H	Hold Outgoing Call
h	Hold Incoming Call	L	LCR Outgoing Call
N	Network Incoming Call	O	Outgoing (non-LCR) Call
S	DISA Incoming Call	T	Transfer Outgoing Call
t	Transfer Incoming Call	W	Closed Numbering Outgoing Call
A	Abandoned Incoming Call		

- ② Call Start Time (Month/Day, Hour:Minute:Second)
- ③ Call Duration Time (Hours:Minutes:Seconds)
- ④ Trunk User No. (Internal Line No. 0 to 9999, or Trunk No. C1 to C576)
- ⑤ Trunk No. (1 to 576, or *1 to *576 when trunk is disconnected while the call is on hold)
- ⑥ Dialed No. (24 digits max., including 0-9, *, #. Hidden numbers will appear as * instead of digits. Format #2 only: "I" precedes digits for incoming calls. Security/Access Codes will not appear as dialed digits.)

- ⑦ Account Codes (Unverified: 10 digits max., or Verified: either first 4 digits, or Code Pgming Table No. V100-V500)
- ⑧ DISA Security Code (Pgming Table No. D001-D016)
- ⑨ Caller Data (Format #2 only)
- ⑩ ISDN Charge Data (Format #2 only -- Not Used/for future use)
- ⑪ Call Ringing Duration (Format #2 only; includes abandoned calls)
- ⑫ Carriage Return Line Feed

NOTE: Centrex and PBX codes, DISA security codes, and ARS access codes will not appear as dialed digits.

If the Caller ID Feature is installed and enabled, "Private" will appear for calls with restricted Caller ID display. "Out of Area" will appear for long-distance calls that do not provide Caller ID information.

Benefits:

- Provides accounting management tool for allocation of telephone expenses.
- Identifies areas for system or feature upgrade.
- Provides customer with record of telephone usage which can be used in making budgetary and planning forecasts.
- Prevents telephone abuse and misuse by identifying unauthorized outgoing calls.
- Provides personnel evaluation tool to measure amount of employee's time spent on the telephone.

Applications:

- Customers whose operation requires call tracking capabilities (e.g., lawyers, consultants, etc.)

SYSTEM SPEED DIALING (SSD)

Description:

The system can store up to 800 SSD bin numbers that can be accessed by any user. Selected users can program the SSDs on their extension phones (if their phones are enabled for it in programming).

The phone numbers stored inside the SSD bins can be up to 24 digits in length. End-users can "chain" up to 6 SSDs together inside a PSD (Personal Speed Dial) bin, to handle phone numbers that are longer than 24 digits. Also, the system can be set to automatically access a trunk group whenever an SSD is dialed (so you won't have to program trunk access into the SSD bins).

On a proprietary telephone, an SSD number can be dialed by pressing a pre-programmed Flexible Feature (FF) key, or by pressing "Auto" and dialing the SSD bin number (00-79 or 000-799). Or, on display phones, the user can display an SSD Index that shows a list of current SSDs in the system, and press the soft key next to the desired SSD to dial it automatically.

Individual phones can be programmed to display (or not display) the actual phone number being outputted for the SSD.

The DBS 576 can be programmed so that SSDs will override any toll restrictions that would normally apply.

Benefits:

- Saves time and increases productivity by allowing the user to use abbreviated dialing to access frequently-called numbers.
- Provides a way for users to store frequently-used feature codes into SSD bins for easy, one-touch feature activation.

Applications:

- General business environment where many people call the same locations or customers

TOLL RESTRICTION SERVICE (TRS)

Description:

TRS lets you control user access to outside lines on a per-station and per-line basis. It can be combined with ARS to block calls based on the number dialed, the outside line used, the extension phone used, the time of day (via Day, Night and Night 2 modes), and/or the day of the week/month/year.

- A TRS Class can be assigned to each extension and trunk. Up to 50 different TRS Classes are available.
- Each TRS Class is then assigned to a TRS Level. It is this Level that is used as the basis for allowing/restricting calls.
- There are 10 TRS Levels available. Level 0 denies all calls. Levels 1-8 can be partially restrictive per assignments. Level 9 allows all calls.
- TRS can restrict the number of digits dialed (1-20 digits, or no limit).
- TRS can restrict the use of SSDs for outdialing, based on TRS Class assignments. Either all SSDs or a range of them can be restricted.
- TRS can also restrict the dialing of * and #, again based on TRS Class assignments.
- The same phone can have different TRS restrictions during Day and Night modes.

Benefits:

- Controls toll calling expenses by allowing the customer to define an individual station's capability to use outside CO line groups.
- Prevents toll calling abuse by providing automatic blocking of calls placed to restricted phone numbers.

WALKING TRS

Description:

A user can use his or her calling privileges at another extension by entering a 4-digit (0-9) ID code. This enables the other extension to temporarily have CO line access capabilities which are defined by the Toll Restriction Service (TRS) data of the user's extension. When the user hangs up the telephone, the extension returns to its original TRS type. This allows a user to make a call from a telephone that is normally restricted, such as a warehouse phone or lobby phone.

NOTE: The Walking TRS code must be programmed at the user's extension before it can be entered at a different extension. The same code can be programmed on multiple extensions. The entered code will show up on the SMDR report as: "Wnnnn" (W means Walking TRS code; nnnn is the 4-digit code).

Since a phone can have a different TRS Class assignment during Day, Night and Night 2 modes, the Walking TRS codes will follow these assignments. For example, long-distance calls can be allowed on the phone during the day, but restricted at night.

Benefits:

- Allows a telephone to be restricted, but still allows certain users to override the restriction.

Applications:

- Warehouse telephones, waiting area, etc.

List of Available System Features

System Feature	Notes
Alarm Ringing	to alert other users of unanswered calls
Alarm Tone	to alert the user of a lengthy CO call
Analog (AEC) Disconnect Signal	for quick-disconnect from 3rd-party Voice Mail systems
Analog Device Compatibility	
Attendant Group	up to 20 phones per Att.Group; each system mode (Day1, Day2, and Night) has its own Att.Group
Auto Day/Night Mode	system automatically switches modes at preset times
Automatic Route Selection (ARS)	least cost routing
Automatic Trunk-to-Trunk Transfer	automatically connect two outside calls together
Background Music (BGM) / Music-on-Hold (MOH) Separation	a different music source for each
Battery Backup	can support the phone system for up to 30 minutes at a time
Behind PBX/Centrex Compatibility	
BLF Ringing	FF-keys can be programmed to represent other extensions
Building Block Configuration	up to 6 cabinets per system
Built-In 2-Way Voice Mail	with 2-way call recording/storing capability
Built-In ACD	basic Automatic Call Distribution functions
Call Progress Tones	dial tone, busy tone, ringback tone, error tone, confirmation tone, splash tone
Caller ID	LCD Display, Call Log, CTI, SMDR (available on display phones only)
Centralized Attendant	one Attendant position for all extensions in a tie-line network
Centralized Voice Mail	one VM system serving multiple PBXs in a tie-line network
Class of Service (COS)	CO/Tie-Line feature, Extension feature Extension-to-Extension and Trunk-to-Trunk restriction
Closed Numbering	for networking systems together
CO Trunk Interface	DID, E&M Wink-Start, Ground-Start, ISDN BRI and PRI, Loop Start, T-1
Computer Telephony Integration (CTI) Capability	TAPI, PC Phone, PC Attendant
Conferencing	3-party to 8-party conferences, including up to 7 outside lines; 2-party private conversations during a conference

System Feature	Notes
Data Security	for SLT devices
Delayed Ring	separate controls for Day/Night Modes
Digital Pad Settings for Volume Adjustment	dB volume adjustments between different connections
DID/DNIS (Direct Inward Dial/ Dialed Number Identification Service)	delayed ringing, direct to Voice Mail, multiple-ringing, name display, night ringing assignments
DISA (Direct Inward System Access)	Outside callers dialing-in on a DISA trunk can use internal features such as paging, transfer, outside-line access, etc. Up to 16 DISA Security Codes can be assigned for outside-line access, each Code with its own TRS Class of Service.
Distinctive Ringing	for both individual CO lines and stations
Door Box Connection	CO connection
Doorphone	Visitors at a locked outside door can call a user, who can open the door by dialing a code on the desktop phone.
Flexible Numbering	1-4 digits in Extension Nos.; changeable Feature Access Codes
Flexible Station Functions	(available on large-display phones only)
Free Slot Configuration	most cards can be installed in any flexible slot
Hot Line	up to 20 phones can be programmed to automatically call another extension or SSD when the user goes off-hook
Howler Tone	an alarm for abnormally long off-hook/dial-tone conditions
Hunt Groups	Pilot No.; Circular/Distributed/Switchback/Terminal hunting; Attendant Hunt Groups; Extension Hunt Groups
ISDN (Integrated Services Digital Network)	T-point/S-point BRI and PRI
Maintenance	local and remote
MCO Tenant Groups	trunk groups can be assigned to different phone areas within the same system, for outside-line access and incoming calls
Memory Backup	on-site or via remote computer
Multiple Ringing	the same trunk call ringing on multiple phones via DSS/BLF keys, CO/MCO keys, and Directory Numbers (up to 3 PDNs and 3 NPDNs per phone)
MOH (Music-On-Hold)	external and internal sources
Non-Blocking Architecture	all extensions/lines available for use at the same time
Page Zones	up to 5 external/10 internal page zones per system; UNA calls over paging system (all or per-zone)
PC Based Programming	PC Customized Tool (proprietary)
Port/Channel Close (“Station Lockout”)	trunk/extension ports can be disabled for use
Power Fail Transfer	Up to 4 SLT phones can automatically receive dial tone from a trunk line in the event of a power failure.
Power-On Maintenance	for extensions and trunks
Privacy	includes Privacy Release
Private Networking (E&M)	two or more PBXs in different locations, connected together in a tie-line network
Program Data Output	for maintenance/troubleshooting
Recall Timers	system-wide or station-specific

System Feature	Notes
Slide Ringing	delayed ringing for FF-key line appearances
Soft Key Operation	(available on display phones only)
Speed Dialing (SSDs/PSDs)	2-digit or 3-digit SSD codes (up to 80 or 800 per system); 2-digit PSD codes (up to 20 per phone)
Station Message Detail Recording (SMDR)	includes abandoned calls
Station Name Assignment	up to 10 characters each
System Fault Recording	Bus Monitor; storing/printout via programming
System Speed Dial (SSD)	up to 800 SSDs per system; name assignments for display phones; toll restriction override
T-1 Networking	T-1 point-to-point private networks (E&M)
Tandem Connection	E&M and T-1
Telephone Programming	(available on display phones only)
TRS (Toll Restriction Service)	Outgoing calls can be allowed/blocked based on the path (originating ext.-to-seized-trunk) and dialed digits.
Traffic Measurement	trunk (separate inbound/outbound) and intercom call traffic; 30-minute interval storing/printout via programming
Trunk Groups	inbound and outbound; up to 99 groups per system; 96 members/cabinet in each group; MCO trunk group chaining
Trunk Name Assignment	(available on display phones only)
UNA (Universal Night Answer)	incoming calls ringing over the paging system
Virtual Ports	for multiple ringing, floating park, etc.
Voice Mail Integration	built-in and 3rd-party analog/digital
Walking TRS	codes for overriding TRS on a phone

Chapter 4 - Station Features

Overview

This chapter describes the many features that end-users can perform on DBS 576 station phones. Some of the most popular functions are highlighted below. A complete list of Station Features is included at the end of this chapter.

Popular Station Features

ACCOUNT CODE CAPABILITY

Description:

This feature works with Station Message Detail Recording (SMDR). During a phone call, a station user can silently enter an accounting or client billing code. The entered Code will display on the phone's LCD as it's dialed, so the user can tell it's being registered. Subsequent SMDR reports will show the Code dialed for each call.

There are two different types of account codes you can use in the DBS 576:

Non-Verified Account Codes: Codes that aren't checked by the system for validity; the user can enter anything from 1-10 digits long. Individual phones can be programmed to accept *forced* Account Codes (the user must enter a code for every call) or *voluntary* Account Codes (the user can enter a code, but doesn't have to, for each call).

Non-Verified Account Codes can be assigned to incoming and/or outgoing calls. For incoming calls, the user can enter the Code anytime during the call. For outgoing calls, the user either enters the Code before accessing an outside line (for *forced* Codes), or anytime during the call (for *voluntary* Codes).

Verified Account Codes: Codes entered by phone users that must match a code of up to 10 digits that has been preprogrammed into an Account Code Table. If the dialed Code doesn't have a matching entry in the Table, the user gets fast-busy and is unable to place the call. These codes can also be either *forced* or *voluntary*. You can program these codes with their own Toll Restriction Service (TRS) Class assignment so that, when entered, they will override the extension's TRS Class (which would normally be used to allow/restrict the call).

Benefits:

- Provides a way to allocate telephone expenses (outgoing calls) to specific clients/departments as a cost accounting tool.
- Doesn't limit the expense allocation by phone; the Account Codes are specific to the phone *users*, not to the *phones*.
- Displays the entered Account Code on the phone's LCD, allowing the user to verify it immediately.
- Provides record-keeping confidentiality by allowing the user to enter the Account Code while the call is in progress, without interrupting the conversation or showing any other indication to the outside party.

Applications:

- Customers who need to track outgoing calls so they can bill clients such as lawyers, accountants, etc.
- Customers who allocate phone call expenses by project

ALARM RINGING

Description:

If an incoming trunk call rings unanswered for a (programmable) period of time, the call's ringing pattern and dB level changes automatically so users can tell which calls have been ringing longer. You can program the pattern of the ringing. You can also enable this feature on some trunks, and disable it on others.

Benefits:

- Users can distinguish between calls that have been ringing longer than others.

Applications:

- Noisy office environments; heavy call traffic

ALARM TONE FOR LENGTHY CALLS

Description:

If a user is on a phone call for a long time, an alarm tone sounds intermittently in the handset receiver. This feature can be turned on/off system-wide in programming. If you turn it on, you can also enable/disable individual phones and trunks for it, as well as programming the amount of time before the alarm goes off.

Benefits:

- The DBS 576 can automatically monitor call duration, and let users know when they've been on a phone call too long.

AUTO-REPEAT DIALING

Description:

If a user places an outside phone call and gets a busy tone, he/she can stay on the line and press REDIAL. The DBS 576 will automatically send a Flash signal, redial the call, and wait to detect busy tone on the line (note: this doesn't work on E&M tie-lines or ground-start trunks). If the line is still busy, the system will try again and again, at programmable intervals, until one of the following happens (whichever occurs first): 1) the called party answers; 2) the user hangs up; or 3) the system tries 14 more times.

You can turn this feature on/off for individual extensions, and also enable/disable it on individual trunks. You can also program the amount of time the system waits to detect busy or answer, as well as the interval between redial attempts.

Benefits:

- An automatic feature that helps phone users save time and reduce dialing errors.

BACKGROUND MUSIC (BGM)

Description:

Users can set their phones to play Background Music on-speaker while the phone is idle. If the phone receives a call, or the user goes off-hook, BGM will go away until the phone becomes idle

again. BGM can be turned off by dialing the same code that turned it on. BGM can have a different sound source than Music-On-Hold (MOH) (what callers hear when they get put on hold).

Applications:

- One sound source for employees (BGM, typically music), another for callers (MOH, such as recorded advertisements).

BUSY OVERRIDE (“BARGE-IN”)

Description:

An extension user can barge into a call on another extension, whether it’s an outside or intercom call. Phones set to Do-Not-Disturb (DND) can also be barged into; see **DO NOT DISTURB** for more information.

When a barge-in occurs, a 3-party conference call is created; all three parties can hear each other and talk to each other. There are two ways to barge-in on a call:

- Extension Busy Override**, where the user dials the extension, gets busy tone, and dials a code to barge-in.
- CO Key Busy Override**, where the user presses the lit CO line key on his/her phone that represents the call in progress.

You can program the DBS 576 to send an alert tone to all parties when the barge-in occurs. You can also allow/block the phone’s ability to perform this feature based on the phone’s Class of Service assignment (see **CLASS OF SERVICE RESTRICTION** in *Chapter 3 - System Features* for more information).

Benefits:

- Allows operators, secretaries, bosses, etc. to interrupt calls in progress with urgent information or other calls that need to be answered.
- Provides a way to establish a 3-party conference between two users and an outside party, or between three users.

CALL DURATION DISPLAY

Description:

The length of a call in progress (minutes and seconds) is tracked and displayed on the phone’s LCD.

Benefits:

- Users can tell how long they’ve been on a call -- and what the SMDR report is going to show for that call.

CALL FORWARDING

Description:

Call Forwarding allows users to automatically send their calls to another extension, to an outside line, or to voicemail. There are several different types of call forwarding that can be set:

- All Calls
- If Busy
- If No Answer
- If Busy or No Answer
- Call Forward/Outside

All types can be set or cancelled manually by the phone user (you can allow/disallow this ability for groups of users in programming). Most types can also be programmed on a permanent basis. The user can also clear the phone of all of its Call Forward and DND settings with a single code. Users can also set/clear Call Forward settings on other extensions from their own phones. (This can all be allowed/disallowed in programming.) The DBS 576 also provides timers in programming for ringing duration before and after call forwarding.

Benefits:

- Provides a way to pick up calls for absent personnel who are not part of a call coverage group.
- Allows for integration of Voice Mail systems.

Applications:

- Sales, marketing, customer service, etc.
- Companies using Automated Attendant and/or Voice Mail

CALL PARK

Description:

This feature is often used with Paging. It's a type of transfer that doesn't involve the phone ringing; you simply "move" the call to another location. There are three types of Call Park:

- System Park.** Also known as Park Orbit or "Floating" Park. Users can park the call to an orbit (ie., Virtual port), and page the person to pick up the call from any extension by dialing a Park Pickup code and the orbit number.
- Remote Park.** The call can be parked onto another (physical) extension, when the user wants to walk over to another desk and conduct the call from there.
- Station Park.** The call can be parked on a user's phone, and retrieved from another phone.

If the parked call isn't picked up within a programmable timeout, it will return to (begin ringing) the original extension again.

Benefits:

- Better call handling capabilities.
- When a party cannot be reached at his/her phone, a user can "park" the call and page the party to pick up the call.

CALL PICK-UP

Description:

Phone users can pick up calls ringing on another (single) extension, other (multiple-ringing) extensions, in an Extension Group, on a specific trunk, or in an MCO Trunk Group. Almost any type of call can be picked up, including DID/DISA calls, network calls, and voice intercom calls.

Benefits:

- Allows phone users to pick up calls, no matter where they're ringing, without leaving their workstations.

Applications:

- Customers who need call coverage for unattended stations
- Organizations with department structure
- Customers who presently have a key system (1A2) operating behind a PABX to provide group pick-up capability

CALLBACK REQUEST

Description:

A phone can alert the user when another, busy extension becomes free. Say Extension “A” calls Extension “B” who is busy. “A” can dial a Callback Request code, hang up, and concentrate on other things. When “B” becomes free, “A” will ring. When the “A” user picks up the handset, the “A” phone will automatically ring the “B” phone. (Or, “A” can change their mind and cancel the Callback Request.)

Benefits:

- The user doesn’t have to keep redialing a busy extension; the phone does all the work.

CAMP-ON (CALL WAITING)

Description:

You can program phones to be able to “camp-on” calls to other extensions. This in effect “queues” the call onto a busy extension. On phones that are programmed for **Automatic Camp-On**, put the call on hold, dial the extension to transfer the call to, and hang up. For **Manual Camp-On**, users dial a Camp-On code before hanging up. The busy extension will receive a splash tone on-speaker (this tone can be turned on/off in programming).

To pick up a camped-on call, either hang up from the current call and then go off-hook again, or put the current call on hold. You’ll be automatically connected to the caller.

Benefits:

- Users only have to call a busy extension once. They don’t have to wait for the station to become free, or interrupt the current call, to transfer a waiting call to it.

Applications:

- Any user who wants to be notified of another call, without the current caller being aware of it
- Attendants who don’t have time to wait for extensions to become free before transferring calls to them

DO-NOT-DISTURB (DND)

Description:

DND enables station users to stop all transferred intercom and CO calls from ringing their station, but still be able to make outgoing calls. Anyone who calls the DND station will hear a distinctive busy signal. But individual phones can be programmed with the ability to override DND settings on other phones. The DND On/Off code can be programmed into an FF-key; the user simply presses the key to activate DND (key LED will be lit red), or turn it off (key LED will extinguish).

Benefits:

- Enables a user to quickly and easily initiate privacy for important meetings, etc.

DP-TO-DTMF SIGNAL CONVERSION

Description:

While on a DP (dial pulse) trunk, a user can switch to DTMF (dual tone multi-frequency) signaling by pressing the * or # key. DTMF signaling is required whenever additional digits are dialed after connecting to an automated answering system such as Voice Mail, Auto Attendant, etc.

You can program the DBS 576 to automatically change DP to DTMF tones based on incoming and outgoing timer programming for each trunk.

Benefits:

- Doesn't limit users to certain trunks whenever they have to dial additional digits.

Applications:

- Users dialing into a Voice Mail or Auto-Attendant system on a DP trunk. They'll need to switch to DTMF signaling to select Voice Mail options by dialing numbers on the phone when prompted. (for example, they'll hear: "To reach Sales, press 1. To reach Purchasing, press 2.")

DSS/BLF KEYS

Description:

With the Direct Station Select/Busy Lamp Field feature, a phone's FF-key can be programmed to represent another extension. The FF-key can be programmed to do one of the following:

- Monitor the extension's current status.** The DSS/BLF key will be lit red when the extension it represents is currently busy. It'll flash when there's an incoming call ringing to that extension. Or, it'll be blank (unlit) while the extension is idle.
- Call the extension.** Just press the (unlit) DSS/BLF key to ring the extension or transfer a call to it. No pressing Hold, no dialing the extension number, no transfer codes. Just press the DSS/BLF key.
- Immediate-ring the extension's calls to your phone.** The DSS/BLF key will flash and your phone will ring at exactly the same time the extension is ringing. Just pick up the handset to connect to the caller. (Or, press the flashing DSS/BLF key if the phone isn't ringing.)
- Delay-ring the extension's calls to your phone.** After a programmable period of time, your phone will start ringing for the extension's unanswered calls. Pick up the handset to answer the call.

Benefits:

- Users can monitor calls to other extensions, and answer them if no one else does.
- Users can transfer calls to an extension simply by pressing the DSS/BLF key for it.

Applications:

- Receptionists, secretaries, operators -- anyone who needs a quick and simple way to get calls to, and receive them from, other extensions

DUAL-COLOR LEDS

Description:

Each LED key has dual colors underneath. Red is a busy CO line and green is the CO line you are speaking on. These dual colors are utilized to indicate busy or DND stations.

Benefits:

- Lets users know what CO line they're talking on; especially useful for calls on hold.
- Helps users monitor the status of stations (if the key is being used as a DSS/BLF).

Applications:

- Systems that are designed as "squared," and multiple lines appear on telephones
- Boss/Secretary applications

FLEXIBLE FEATURE KEYS (“FF-KEYS”)

Description:

Every FF-key on a telephone can be programmed by the end-user for a variety of one-touch features. The following is a list of some of those features:

- Absence Messages
- Account Codes
- Alarms
- Answer Key
- Barge-In
- BGM
- Call Forwarding
- Call Park
- Conferencing
- Direct Appearing CO Lines
- Direct Call Pickup
- DND
- DSS/BLF
- Group Call Pickup
- Headset On/Off
- Meet-Me Answer
- Message-Waiting Send
- Multiple CO Line Access
- Mute Key
- Night Mode
- Paging
- Release Key
- Speed Dialing
- Station Lockout
- Switch to Voice Calling
- Transfer Key
- Voice Mail Access
- UNA Pickup

Benefits:

- Flexibility to custom-configure a telephone to suit the individual user’s needs.
- Easy one-touch feature access, instead of having to remember (and dial) codes.

HANDS-FREE ANSWERBACK

Description:

Station users receiving an intercom call can answer a Voice call on-speaker, without picking up the handset or otherwise touching the phone. Individual phones can be initially set for Voice calling via the Extension COS (Class of Service) assignment in programming. Extensions can also be individually enabled or disabled for Send Voice Calls and Receive Voice Calls (again, via the Extension COS assignment). If a user begins a Tone call, he/she can switch to Voice calling by dialing “1” or pressing a programmed key. A “splash” tone alerting the called party of the on-speaker condition can be enabled/disabled system-wide.

Benefits:

- Users can answer intercom calls without touching the phone.

HEADSET CAPABILITY

Description:

A proprietary phone’s FF-key can be programmed for activating/deactivating Headset Mode on the phone. When it’s activated (FF-key LED is lit red), all audio for the phone (including the speaker) is switched to the Headset jack, and the “RELEASE” and “ANSWER” buttons replace handset on/off-hook functions.

During Headset Mode, headset users can activate Zip Mode (automatic answer of the next incoming call); the user will hear a short notification tone (double-beep) before connecting to the caller. Also, individual phones can be programmed to lower the dial-tone volume when the headset user accesses an outside line.

Benefits:

- Increases user efficiency by allowing headset operation from any proprietary telephone, eliminating the need to lift or hang up the handset.

Applications:

- Attendant position, customer service, etc.

HOLD

Description:

With its variable Call Holding features, the DBS 576 lets you control who can pick up a call on hold:

- System Hold:** Anyone can retrieve the held call from any phone.
- Exclusive Hold:** Only the person who put the call on hold can retrieve it.
- Station Park Hold:** Users can “park” a call at any phone (effectively putting it on hold there), and retrieve it when they’re ready.
- Floating Hold:** A kind of System Park where the user can transfer the call to a Floating Hold key, and any phone with that key (set according to a programmable dial plan) can pick up the call.
- Brokers Hold:** A user can toggle between two calls by pressing HOLD (one call is current, the other is on hold).

Benefits:

- You can limit the number of people who can pick up a call on hold.
- You can allow anyone to be able to pick it up, no matter where it’s put on hold.

HOT DIAL PAD

Description:

A user can simply walk up to a digital phone and start dialing without picking up the handset. The call immediately switches to the phone’s speaker, and the entire call can be conducted on it. Of course, the user can pick up the handset anytime to take the call off-speaker.

This feature can be enabled/disabled on individual extensions in programming. There is no limitation on the number of digital phones that can have Hot Dial Pad. It’ll work whenever the phone is idle, has another call on hold, or is receiving a page.

Benefits:

- Calls can be initiated hands-free (no handset required).

Applications:

- Fast-paced environments
- Emergency-dial situations

HOT LINE

Description:

When somebody lifts the handset, the phone automatically dials a preassigned extension or speed-dial number. (The user doesn’t dial any digits.)

Applications:

- Lobby areas, elevators, etc. (for example, a sign above the phone that reads “*For assistance, pick up the phone*”)

MEET-ME ANSWER

Description:

With Meet-Me Answer, a user can answer a page from any extension without having to run to a certain phone. All the user has to do is pick up the handset on the nearest phone, and dial the universal Meet-Me Answer Code (the default Code is ##) to connect to the initiator of the page.

Benefits:

- Users can answer their calls from any phone in the building.
- Attendants don't have to chase people down to relay important messages.

MESSAGE-WAITING/CALLBACK

Description:

This is similar to Call Waiting. The difference is, the called party isn't as obligated to call you back when they get off the phone. The Message-Waiting LED will blink on the called party's phone, and its LCD will also indicate the Message-Waiting callback request. The called party can go off-hook and press the MSG key to call you back. Or, he/she can ignore it. (The indications won't go away, but they won't interrupt anything else from happening on the phone, either.)

Benefits:

- A more polite, less urgent way to ask someone to call you back, when they get a minute.

Applications:

- Voice Mail. Whenever users get a new message in their mailbox, this is how the phone lets them know.

MUTE

Description:

Mute is often used as an alternative to putting a caller on hold. Say a station user is on a call. The boss walks up and start silently mouthing words to the user. Instead of putting the caller on hold, the user can press an FF-key programmed for Mute, to block audio to the outside party (or, if the call is on-speaker, press the MUTE button). The user can still hear the outside party. But the outside party can't hear the user. Or the boss, who can now speak freely. The user can re-establish audio by pressing the FF-key or MUTE button again.

Benefits:

- There is no indication to the outside party (other than silence) that he/she can't hear the station user anymore.

NAME ASSIGNMENT

Description:

The DBS 576 lets you create a more user-friendly, personalized system by allowing various name assignments that will display on phone LCDs. You can assign names to:

- CO Lines
- DID/DNIS Numbers
- Extensions
- Extension Index
- Personal Speed Dial (PSD) Codes
- System Speed Dial (SSD) Codes

SSD Index

Benefits:

- Lets users look up a phone number by name, and have the phone dial it automatically.

Applications:

- Executive suites, doctors offices, travel agencies

OFF-HOOK MONITORING

Description:

With Off-Hook Monitoring, a call can be conducted through the handset and on-speaker at the same time. After lifting the handset and placing/answering a call, the user can press the ON/OFF key to “share” the call on-speaker. The outside party can be heard both in the handset receiver and through the speaker. But the outside party can hear the user only if he/she is talking into the handset. (The spf microphone in the phone’s speaker won’t transmit.) NOTE: This feature isn’t available during Headset Mode.

Benefits:

- Others nearby (such as Supervisors) can listen in on a call without conferencing-in.

OFF-HOOK SIGNALING

Description:

This applies to calls with multiple-line appearances (those calls that ring on multiple phones). Off-Hook Signaling sends a tone to a busy extension to indicate that another CO call has arrived. Off-Hook Signaling applies to direct calls, Automatic Camp-Ons, and Manual Camp-Ons.

Benefits:

- The user (especially the Attendant) knows when a second or third call is ringing in.

OFF-HOOK VOICE ANNOUNCE (OHVA)

Description:

This is a type of barge-in that doesn’t include the outside party. A station user calls a busy extension and wants to break in. So he/she dials a code, and tells the busy extension of the important message. The busy extension user can (if desired) press a preprogrammed OHVA key to mute conversation to the outside party, and connect to the user who’s trying to relay the message. In the meantime, the outside party doesn’t hear what’s going on behind-the-scenes. To resume normal conversation with the outside party (and disconnect from the extension that broke in), press the OHVA key again.

Benefits:

- Allows more flexibility for users who want to be alerted that there are other calls or important messages waiting, without putting the outside caller on hold.
- Confidentiality.

Applications:

- Boss/Secretary relationship
- Any office environment

ON-HOOK DIALING

Description:

With this feature, station users can dial out without picking up the handset, by pressing the ON/OFF key and then dialing the number. They'll hear everything -- dial tones, DTMF signals, talk, etc. -- through the phone speaker. To take the call off speaker, just lift the handset.

Benefits:

- Easier dialing.
- Hands-free phone conversations on speakerphones.

ONE-TOUCH KEYS

Description:

DBS 576 phones have several different types of keys that can be programmed to execute features or store frequently-dialed numbers. Instead of dialing a series of digits, the user can just press the key. There are **FF-keys** (with LEDs that flash red or green, indicating certain features or phone status), **Labeled Keys** (that perform a specific function such as Hold, Flash, Mute, etc.), **Soft Keys** (surrounding the phone's LCD, that execute the feature name that's displayed on the LCD), and **One-Touch Feature Keys** (solid one-touch keys, not available on some phones, that store additional feature codes or frequently-dialed numbers).

Benefits:

- Gives users many one-touch options for performing features such as CO line access, camp-ons, barge-ins, etc.

PAGING

Description:

The DBS 576 allows users to make both *internal pages* (heard on phone speakers) and *external pages* (heard over a loudspeaker system). Users can respond to pages for calls on hold with Meet-Me Answer. You can create up to 10 different internal and 5 different external paging zones, and an extension can belong to more than one of them. Paging Override settings are also available.

Benefits:

- Improves operating efficiency by providing dial access to paging equipment and to stations in designated paging zones.
- Improves customer satisfaction by facilitating a faster response to callers on hold.

PRIME LINE PREFERENCE

Description:

A phone can be programmed to automatically access an MCO trunk when the user goes off-hook or presses ON/OFF.

Applications:

- Users who need instant access to an outside line.

RINGING LINE PREFERENCE

Description:

This feature gives station users the ability to answer a ringing incoming call simply by lifting the handset or pressing ON/OFF. If this feature is disabled on the phone, the user must press the flashing CO line key to answer the call.

Benefits:

- Users can pick up calls quickly.

Applications:

- Easier access to ringing calls
-

SOFT KEY VARIABLE MODE

Description:

Soft Key Variable Mode allows Small-Display phone users to access frequently-used features through their soft keys, while the phone is in different call states such as during intercom call, during CO dial tone, during a trunk call, and during busy tone (after calling a busy extension).

Benefits:

- Provides easy feature access via customized phone keys.
 - Displays the feature name next to the soft key during the call state in which it's available.
-

SPEED DIALING

Description:

Users can program any of their one-touch keys for speed-dialing. There's **Personal Speed Dial** codes which can be different on each extension (up to 20 PSDs per phone). There's also **System Speed Dial** codes (up to 800) that can be used by everyone. Some of the wonderful things you can do with these speed-dial codes in programming:

- Set individual extensions to be able to override TRS restrictions with SSD numbers.
- Chain SSDs and PSDs together (useful for entering account codes, navigating through automated answering machines, etc.).
- Divide the SSDs into blocks and assign them to different phone areas.
- Set the system to automatically select a trunk whenever an SSD or PSD is dialed.

Benefits:

- Saves time and increases productivity by allowing one-touch dialing of frequently-called numbers, or one-touch feature activation.
-

TRANSFER

Description:

The DBS 576's Transfer feature allows station users to transfer their outside line or inter-station calls without attendant intervention. Transferring calls can be either *supervised* by the user (who waits for the third party to answer, then announces the call before transferring it) or *unsupervised* (user hangs up before the third party answers). If the third party doesn't pick up, the call will return to the extension that originated the transfer. If that extension doesn't answer it either, the call will revert to the Attendant Group.

Benefits:

- Provides efficient, user-friendly call handling capabilities.

WALKING TRS

Description:

By entering a Walking TRS (Toll Restriction Service) code on any phone, a station user can temporarily have access to the less-restrictive call capabilities of his/her own phone. For example, the user can walk over to another phone that is set to restrict long-distance calls, pick up the handset and dial his/her Walking TRS code (which is associated with the user's own phone), and be able to make a long-distance call. When the user hangs up, the phone will return to its original TRS setting.

Benefits:

- Allows a telephone to be restricted, but still allows certain users to override the restrictions.

Applications:

- Warehouse phones, waiting areas, etc.

List of Available Station Features

Station Feature	Notes
Absence Messages	users can set their phones to send one of 10 preprogrammed messages, which will appear on other phones that try to call when the user is absent
Account Codes	10-digit forced or voluntary; 4-digit verified or unverified
Alarm Ringing (phone)	ring pattern changes for unanswered calls
Alarm Ringing (handset)	beep heard by user for a lengthy call
Auto Busy Redial	phone will automatically redial a busy number
Background Music	users can turn BGM off/on on their own phone speakers
BLF Keys	4 modes for representing another ext.
Busy Override ("Barge-In")	creates a 3-party conference
Callback Request	Users can set their phones to ring when another busy extension becomes available.
Call Duration Display	displays the running time duration of a call in progress
Call Forwarding	All Calls, Busy, No-Answer, Outside; Destination/Source Display; Set/Clear on another extension
Call Park	Users can put a call on hold at another phone.
Call Pickup	Direct; Group; Multiple-Line Appearance
Caller ID Log	up to 20 phones/cabinet; up to 10 entries/phone
Camp-On	both automatic and manual
Conferencing	digital phone users can initiate 3-party to 8-party conferences, including up to 7 outside lines; 2-party private conversations during a conference
Dial Tone Shut-Off	Dial tone can be muted.
Direct CO Line Access	Users can select a specific trunk to make an outgoing call.
Direct CO Line Answer	Users can select a specific trunk to answer an incoming call.

Station Feature	Notes
Directory Number Keys	for handling multiple calls simultaneously on the same phone; up to 3 PDNs and 3 NPDNs per phone (plus a direct call ringing in on the "EXT" LED)
DSS/72 (Direct Station Select/72-key) Module	can be used with any digital station phone
Directory Display & Dial	Extension, PSD, SSD directories
Display	call status, called party, calling party, date/time
Distinctive Ringing	for individual CO lines and stations
Do Not Disturb	set/clear on own ext. or another ext.
DP-to-DTMF Signal Conversion	Dial-pulse signaling can be switched to DTMF, either manually or automatically.
DSS/BLF Keys	4 modes for representing another ext.
Dual-Color LEDs	for easier detection of call status/priority
Extension Directory	Users can toggle through a displayed Directory of extensions, and press a soft key to select & call the extension.
EM/24 (Extension Module/24-Key)	attachable to any keyphone; provides 24 extra FF-keys
Flash	for toggling between 2 calls on an SLT phone, or seizing another trunk line without hanging up
Flexible Feature Keys	with dual-colored LEDs; can program executable codes for one-touch feature access
Floating Park Hold and Retrieve	Anyone can pick up a call on Floating Hold.
Hands-Free Answerback	voice calling; intercom calls are established through the phone's speaker (don't have to lift handset)
Hands-Free Operation	Press ON/OFF to put a call on speaker, then hang up and conduct the call over the speaker.
Headset Operation	user-activated; automatic answer; dial-tone muting
Hold	Brokers, Exclusive, Floating, System
Hot Dial Pad	dial without lifting handset
Hot Line	lift handset (no dialing) - the phone automatically dials a pre-programmed number
Interactive Screens	(available on large-display phones only)
Intercom Calling	Tone, Voice
Key Bank Hold	on DSS/72s
Line Appearances	the same trunk line "appears" (via FF-key) on multiple phones
MCO Line Preference	press ON/OFF to seize an MCO trunk
MCO Trunk Access	access an MCO trunk group to make an outside call; the system decides which trunk in the group will be used
Meet-Me Answer	answer an intercom page from any phone
Message Waiting/Callback	send a Message-Waiting signal to another phone; dial a code to automatically callback the Message-Waiting sender
Mute	block audio to the outside party (Tone Calling only)
Name Assignments	Extension, Trunk, SSD, PSD, DID/DNIS, Extension Index, SSD Index

Station Feature	Notes
Off-Hook Monitoring	press ON/OFF to put an outside caller on speaker, and continue to conduct the call through the handset (outside caller can only hear through the handset)
Off-Hook Signaling	phone “beeps” to alert user of another incoming call
Off-Hook Voice Announce	intercom calls on speaker; originate and receive
On-Hook Dialing	via ON/OFF key, or Hot Dial Pad
One-Touch Keys	for feature access/execution
Paging	internal receive; internal/external access; UNA pickup
Personal Speed Dial (PSD)	up to 20 PSDs per phone; Directory; Name Assignment (7 char.)
Prime Line Preference	(“Hot Line”) Go off-hook; system automatically dials a preprogrammed extension number or SSD code.
Redial Last Number	Press the REDIAL key to automatically call the last dialed no.
Ringling Line Preference	Go off-hook to answer an incoming call (don’t have to also press a key).
Soft Key Variable Mode	(available on small-display phones only) Access another set of features by switching to Variable Mode.
Speakerphone	(available on speakerphones only)
Speed-Dialing	System (SSD); Personal (PSD); SSD/PSD chaining
Station Callback Display	(available on display phones only)
Station Function List	(available on large-display phones only)
Station Lockout	users can temporarily change their phone’s TRS Class to restrict others from placing outside calls on it
Step Calling	after calling a busy extension, users can dial only the last digit of the next extension to transfer to it
System Speed Dial (SSD)	up to 800 SSDs per system; SSD Directory; SSD Name Assignment (up to 16 char.)
Text Messages	during Call Waiting/OHVA or Camp-On, a user can send one of 10 pre-programmed messages that will display on the called extension
Time & Date Display	(available on display phones only)
Timed Reminder	phone issues an alarm tone at a pre-set time
Transfer	screened (transfer/wait for answer) and unscreened (transfer/hang up)
Trunk Queuing	(for direct trunk access and MCO-1) Users can “queue” (wait in line) for a trunk to become available.
Trunk-to-Trunk Connection	connect two outside calls together
Voice Mail Transfer Key	transfer calls to someone’s voice mailbox
Voice Recognition	requires Adapter Kit for each phone
Volume Control	handset; monitor (speaker); ringing
Walking TRS	codes for overriding TRS on a phone
Zip Mode	automatically answer next incoming call during Headset Mode

Chapter 5 - Special Applications

Overview

The DBS 576 is designed to accommodate a wide variety of features as described throughout this document. However, this powerful phone system is also designed to support fast-emerging technological trends and specialized 3rd-party product integrations. Listed below are some examples.

Private Networking

Companies with two or more offices can benefit from the DBS 576's powerful networking features by establishing private phone connections between the sites. Typically, companies with multiple sites have a high level of call traffic between them, resulting in astronomical phone bills if they're using the public switching network (COs). In a private network, however, the company pays a fixed rental fee for the private lines, regardless of how often they are used. In fact, the more they're used, the more money the company saves. A private network also provides other benefits, such as increased efficiency by allowing the user to dial an extension number instead of a long-distance number.

The DBS 576 can provide networking features such as:

- Network Call Transfers.** Allows a call at an extension to be transferred to an extension in another network PBX.
- Network Extension Calling.** Allows you to reach an extension on another DBS 576. Based on the number you dial, the DBS 576 network routes the call automatically.
- Network Paging.** Allows users on one DBS 576 system to page on another DBS 576, when the appropriate Class of Service allows.
- Network Call Routing ("Closed Numbering").** Allows multiple systems that are interconnected in a network, to direct calls to a specific tie line based on the number dialed (the call does not leave the network). This allows intercom calls to be conducted between locations that would normally be considered long-distance calling.
- Tandem Connection.** Allows calls over network tie lines to be automatically routed to another PBX, out to the public network, or to internal extensions. The tandem relay function increases network efficiency via automatic routing methods between multiple PBXs, thus reducing the number of tie lines needed.
- Centralized Attendant.** Via tie-line routing, operator calls and associated operator functions (paging, transfer, reversion for unanswered calls) are performed from one Attendant position in the network.
- Centralized Voice Mail.** One voice mail system, installed in one of the network PBXs, serves all extensions in the network. The functions needed for voice mail operation (Call Forwarding to the user's mailbox, Priority Message-Waiting to indicate the mailbox message on the user's phone, and MSG ID Notification for accessing the mailbox and retrieving messages) are simply programmed to be routed over the tie lines.

These powerful networking functions are facilitated by the following DBS 576 hardware connections:

- E&M Tie Lines.** Multiple DBS 576 sites can be connected over leased voice lines.
- T-1 Interface.** Multiple sites (called "nodes") can be tied together through network trunk lines, so that (for example) when one site closes for the day, another node across the country can pick up their calls. Network users can also turn a long-distance call into a local one, by accessing another (long-distance) node and then dialing the (local) number.

Computer Telephony Integration (CTI)

CTI technology ties computers and phone systems together, allowing phone users to combine the advantages of both technologies for fast, accurate, effective response to incoming callers. It's a powerful tool for increasing customer satisfaction, which in turn increases sales for the company that has CTI built into their phone system. For example:

- Customer information could be automatically displayed on a Customer Representative's computer screen, based on the caller's phone number.
- A computer-based phone directory could be used to look up a phone number, and select it on-screen to automatically place the call.
- PBX features such as call transfers, pickups, forwarding, etc. could be executed by clicking on a computer icon or responding to a screen prompt (no more trying to remember a feature access code or sequence).

Panasonic is constantly developing new, more powerful CTI applications to work with the DBS 576. The following describes the CTI products that are currently available.

PC PHONE

Our **PC Phone** is effectively a "Super-Executive Keyphone" which is designed to replace an extension phone. We have redesigned our telephone circuit cards to fit within a PC. Software allows us to replicate the dial pad, LCDs, and keys of the phone which are modeled after the popular "Large-Screen Display" telephone.

Comprised of a PC card (installed inside the computer), application software, and various connecting items (leads, handset, headset, etc.), the PC Phone connects to a DBS 576 extension port and provides a sophisticated "on-screen" phone for the end-user.

PC Phone Connectivity

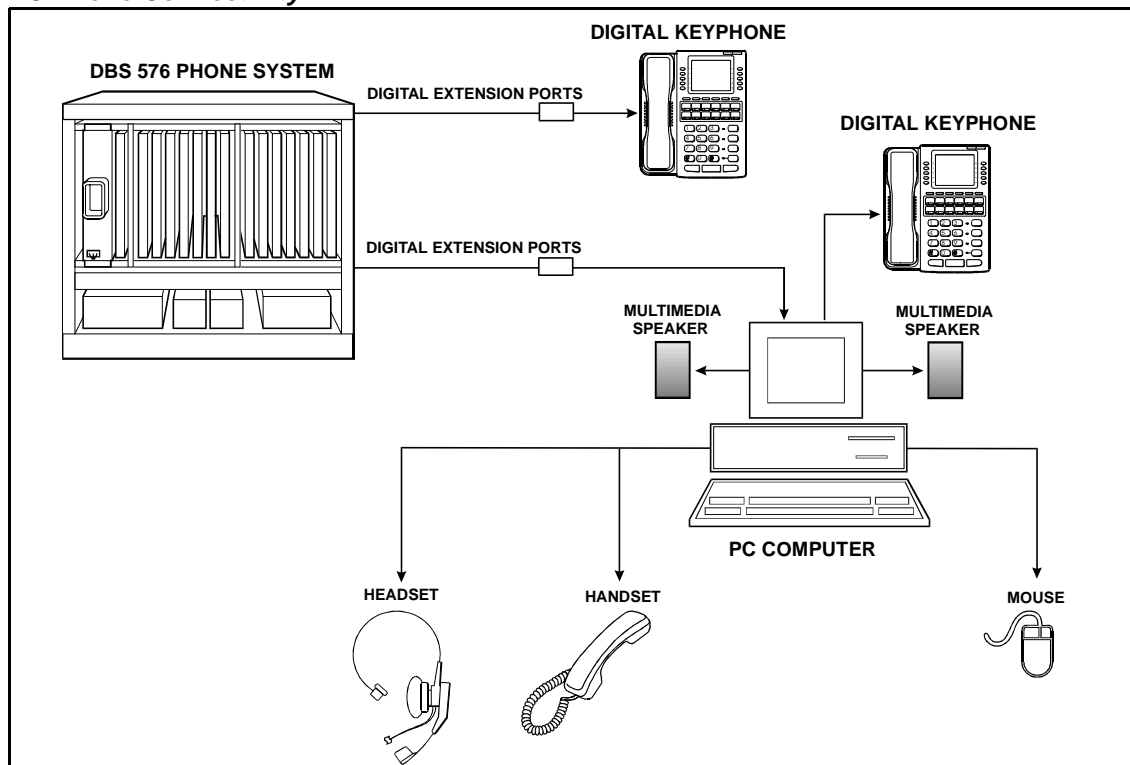

Here's just a few of the many features and benefits that come with the PC Phone:

- ❑ **Flexible configuration.** It's easily configured by size or by features, to provide a simple interface that the end-user can customize to his/her exact requirements.
- ❑ **Easy to use.** DBS 576 features are easily selected via on-screen menus, tool bars, and programmable keys, without the need to consult a user guide.
- ❑ **Online help.** An easy-to-search help facility is available that describes all PC Phone features.
- ❑ **Directory.** An unlimited database of contacts that can be searched by name, address, etc., allowing easy dialing of internal or external calls.
- ❑ **Caller ID.** End-users can identify incoming callers by the number they're calling from (if the CO supports Caller ID functionality).
- ❑ **Call logging.** The PC Phone can record and report every incoming and outgoing call with time, date, duration, calling/called name from directory, etc.
- ❑ **Compatibility with other applications.** The PC Phone comes with a TAPI middleware software package which allows connectivity with many TAPI-compatible software applications such as ACT!, Goldmine, and Maximizer, to name a few.

System Requirements for PC Phone

- CPC-96, CPC-288, or CPC-576 (all versions)
- an 80486 or compatible processor, running at 33 MHz or higher
- 8MB of RAM
- 1.44MB (3-1/2") floppy disk drive
- Microsoft Windows 95 or Windows NT Version 3.51
- Windows-compatible mouse
- 1 spare ISA expansion slot

PC ATTENDANT CONSOLE

The *PC Attendant Console* is for the receptionist/operator position. It is designed to replace the DSS/72 console & keyphone combination that's commonly used as the Attendant.

PC Attendant Console Connectivity

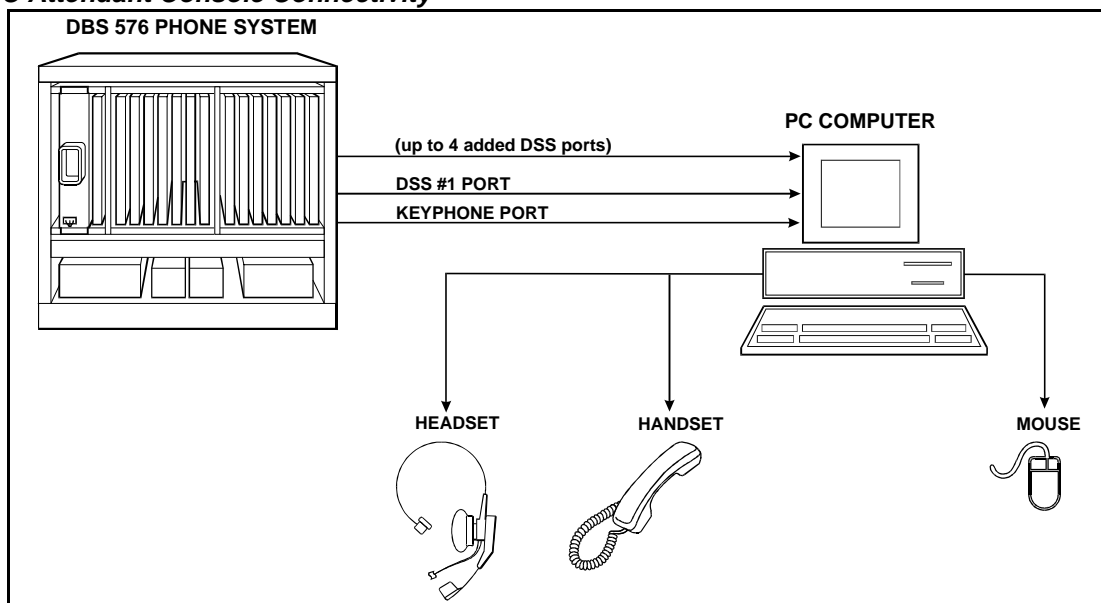

This product is offered in two capacities: a **2-port solution** (equivalent to one 24-key phone with one DSS/72 console) which is capable of monitoring up to 96 ports; and a **6-port solution** (equivalent to one 24-key phone with five DSS/72 consoles) which supports a maximum of 384 ports.

In addition to providing all the features of a PC Phone, the PC Attendant Console will also offer:

- Flexible, scalable Busy Lamp Field (BLF).** One Console can display up to 384 BLFs.
- Line prioritization.** The PC Attendant Console can assign priorities to incoming calls independent and separate from DBS 576 priorities.
- Reporting.** The PC Attendant Console can produce graphical and text reports on system and operator performance.

System Requirements for PC Attendant Console/96 (same as PC Phone)

- CPC-96, CPC-288, or CPC-576 (all versions)
- an 80486 or compatible processor, running at 33 MHz or higher
- 8MB of RAM
- 1.44MB (3-1/2") floppy disk drive
- Microsoft Windows 95 or Windows NT Version 3.51
- Windows-compatible mouse
- 1 spare ISA expansion slot

System Requirements for PC Attendant Console/384

- CPC-96, CPC-288, or CPC-576 (all versions)
- an 80486 or compatible processor, running at 33 MHz or higher
- 8MB of RAM
- 1.44MB (3-1/2") floppy disk drive
- Microsoft Windows Version 3.1x (using Win 32s), Windows 95, or Windows NT Version 3.51
- Windows-compatible mouse
- 3 spare ISA expansion slots

Voice Mail

With the DBS 576, Voice Mail can either be built-in (installed and programmed internally) or external (a third-party application hooked up to the phone system). Both are explained below.

BUILT-IN VOICE MAIL WITH 2-WAY CALL RECORDING

The DBS 576's Built-In Voice Mail option provides simplified Voice Mail functionality. Hardware for this option is installed inside the DBS 576 cabinet, and it is customized in system programming.

Each Built-In Voice Mail system supports up to 248 private extension mailboxes, plus another 6 for general use. Up to 16 users can simultaneously access a single Voice Mail system. A multiple-cabinet system can support up to 4 Voice Mail systems (minimum 4-cabinet configuration).

These are some of the functions of Built-In Voice Mail:

- Extensions can be automatically assigned mailboxes (the mailbox number is the same as the extension number).

- General-use mailboxes can be set up.
- Basic functions of Auto Attendant and backup call answering can be programmed.
- Messages can be “broadcast” (copied) to multiple extensions.
- Calls can be evenly distributed to different mailboxes during auto-answer mode.
- 2-way call recording can be performed. A recording can be either automatically or manually stored as a message in any mailbox.
- 1-digit intercom dialing can be used during Voice Mail service (for example, the caller wants to transfer himself to another extension after leaving a message).
- Automatic notification of a mailbox message to an outside pager or phone number can be programmed.

Specifications for Built-In Voice Mail:

- Maximum Number of Mailboxes: 254
- Maximum Message Storage Time: 40 hours
- Voice Ports: up to 16

PANAVOICE -- PANASONIC'S DIGITAL VOICE MAIL SYSTEM

PanaVOICE is an external PC-based Voice Mail system offered by Panasonic. PanaVOICE is fully digital (connects to DBS 576 digital ports), and comes in an integrated and non-integrated version. The integrated version provides improved messaging via the API port (Message-Waiting indication, constant message count on display phones, visual menus on Large-display phones). See your PanaVOICE documentation for further details.

THIRD-PARTY VOICE MAIL SUPPORT

The DBS 576 also provides features for external Voice Mail products from a third-party vendor. Some of these features are explained below.

NOTE: The fact that the DBS 576 offers these features does NOT guarantee that all features offered by the third-party Voice Mail manufacturer will work with the DBS 576.

VOICE MAIL TRANSFER KEYS

Description:

Users can program any one-touch key on their phones to transfer to a mailbox without waiting for the Voice Mail system to answer. Two Transfer Keys are available. One can be used for external transfers to greetings, and the other for external transfers without greetings.

Benefits:

- Calls can be transferred to a personal mailbox faster, with fewer buttons to press.

MSG KEY

Description:

Large-Display phone users can program the MSG key to retrieve their Voice Mail messages.

Benefits:

- The MSG key is already labeled; it's simple to remember and simple to press.

ONE-TOUCH KEY FOR VOICE MAIL

Description:

Allows a user to program any one-touch key on the phone to automatically dial Voice Mail. The dial number for Voice Mail along with the user's password can be stored under the key. If this feature is programmed on an FF-key or DSS key, the key will flash red when a new message is left in your voice mailbox. This key can also be used by the Attendant to transfer a caller into a specific person's mailbox, by hitting the Voice Mail key and the DSS key for that person.

Benefits:

- Allows a station user to have a larger message waiting lamp for Voice Mail and a quicker way to retrieve messages from Voice Mail.

ANSWER SUPERVISION FOR VOICE MAIL

Description:

The DBS 576 can be programmed to send an answer supervision signal to a 3rd-party Voice Mail or Auto Attendant system, when the extension user answers a call. (Voice Mail doesn't wait for the ringing to stop before releasing the call.)

Benefits:

- Voice Mail releases calls to the extension more quickly.
- The one-touch access and flashing key serves as an excellent tool for prompt voice mail interaction.

DID TO VOICE MAIL

Description:

DID numbers can be assigned to ring directly to a voice mailbox that is not associated with a physical station. When the Voice Mail answers the DID call, automatic digits can be sent to route the call to a specific personal mailbox.

Benefits:

- Station equipment doesn't have to be used for routing incoming DID calls to specific mailboxes.

FOLLOW-ALONG IDENTIFICATION

Description:

When your extension is forwarded to Voice Mail, this feature sends a string of digits when Voice Mail answers. This enables the outside caller to skip the Voice Mail main greeting, forwarding directly to a personal mailbox. Any combination of digits 0-9, pause, * and # (maximum 16) can be programmed to make this feature work, depending on what the Voice Mail manufacturer requires.

Benefits:

- Outside callers are not inconvenienced by having to dial extra digits to reach a personal greeting.

POSITIVE DISCONNECT

Description:

Analog station ports can generate a positive disconnect (open loop) to devices that are attached to them upon hang-up.

Benefits:

- Sending this signal allows quick disconnection from third-party Voice Mail or similar devices.

Automatic Call Distribution (ACD)

ACD provides efficient presentation, handling, and management of incoming calls for phone systems that experience heavy call traffic. Calls can be evenly (or fairly) distributed to different groups of specialized users, called “agents.” And call traffic data can be sent to a PC computer or printer through the DBS 576’s RS232C serial port.

BUILT-IN ACD

Panasonic’s Built-In ACD offers low-cost, easy installation, programming, and operation of ACD functionality. Some of the strong points of this product are:

- One-vendor solution.** There is only one place you have to call - Panasonic - to support and service your ACD. Saves time and eliminates miscommunication.
- Easy installation.** This is a card-type product. All you have to do is insert the unit into the DBS 576 cabinet, and enter a few program settings for it. You don’t need to wire any cable or install any awkward, extra equipment.
- Simple operation.** Agents can use our Large-LCD phones to handle calls efficiently. Agent features can be performed simply by following the prompts displayed on the LCD.
- Easy programming and flexibility.** Use a Large-LCD phone to enter the DBS 576 programming mode, and go to one area of settings specifically for ACD. No special equipment or complicated programming is required.
- Powerful ACD functionality.** Incoming calls can be routed to the first available agent, or transferred to Voice Mail. Supervisors can instantly access the current status of all agents. MIS reports can be generated.

The 576 ACD software can be designed to efficiently handle incoming calls to a group of phones, especially when the entire group is busy. At this point, the caller will be directed to a recording asking the caller to hold, then sent to a Music-On-Hold source until an agent becomes available.

These processing steps are totally flexible and can be changed easily by the supervisor at any time. Utilizing the Large-Screen Display phone, the supervisor can edit the existing script and change the routing. For example, perhaps the office is closed as a result of weather conditions. At this point, the supervisor can edit the script and record a special greeting for incoming callers. This type of quick programmability will greatly increase customer satisfaction.

- Reporting.** Of course, reports are crucial for the group’s activities. These reports can give you enough information to make intelligent staffing decisions. Unlike most of the competition, the DBS 576 ACD system comes complete with reporting capabilities standard! Choose from individual agent activity by week, day, etc., or choose an entire group.

Specifications for Built-In ACD:

- Maximum no. of ACD Units per System: 2 (in a 2+ cabinet configuration)
- Agent Groups per ACD Unit: 3
- Agent IDs per Group: 64
- Maximum Agent IDs per ACD Unit: 64
- Number of Agents Simultaneously Logged In: 32
- Supervisor IDs per Group: 1
- Supervisor IDs per ACD Unit: 6
- Voice Ports per Group: 4
- Voice Ports per ACD Unit: 4
- Music Ports: 1 (on main unit/external MOH source)
- MIS Monitor Ports: 1 (RS232C 9600bps)
- Guidance Length: 1-96 seconds (changeable)
- Number of Guidance Messages: 1-6 (changeable)
- Total Guidance Recording Length: 96 seconds for 6 messages

Chapter 6 - Specifications

Overview

This chapter provides detailed lists of all system specifications in an easy-to-follow table format.

Note: The following specifications are subject to change without notice.

Electrical Characteristics

Power Supply

Equipment	Specification/Requirements
All DBS 576 Cabinets	120 volts AC \pm 10% 60 Hz
Primary Power - Input @ AC: AC Frequency: Watts per cabinet (continuous): Wats for 6-cabinet system (continuous):	85 to 138 volts AC 50/60 Hz 360 watts 2,160 watts
Maximum Peak AC Input Current - 1 cabinet: 2 cabinets: 3 cabinets: 4 cabinets: 5 cabinets: 6 cabinets:	3.3 amps 6.6 amps 9.9 amps 13.2 amps 16.5 amps 19.8 amps
DC Voltage Output Specification:	-24 volts DC (-26.0 to -27.6 volts DC) +5 volts DC (+4.9 to +5.3 volts DC)
AEC (8-circuit card that supports single-line devices such as rotary and DTMF standard phones; FAX machines; dictation equipment; etc.) - Ring Voltage: Ringing Capability:	150 volts p-p 2.0 REN per circuit
Traffic Rating Characteristics:	6 ACS per station system-wide
DBS 576 key telephones	3 watts maximum (powered from the DBS 576)

Battery Backup

Equipment	Specification
Battery Pack: (Part No. VB-44025) Capacity (with maximum traffic):	30 minutes
Battery Charger Characteristics - Charger: Nominal Voltage: Battery Discharge Cut-Off Voltage:	Floating charge 27.2 volts 21.0 \pm 0.3 volts DC

Environmental Requirements

Temperature and Humidity Requirements for System Operation (excluding Built-In Voice Mail)

Environmental Conditions	Requirements
Temperature	32 to 104 degrees F (0 to 40 degrees C)
Relative Humidity	30% to 90% non-condensing
Storage Temperature	-4 to +140 degrees F (-20 to +60 degrees C)

Temperature and Humidity Requirements (Built-In Voice Mail operation only)

Environmental Conditions	Requirements
Temperature	41 to 95 degrees F (5 to 35 degrees C)
Relative Humidity	30% to 90% non-condensing

Dimensions and Weight for Single-Cabinet Systems and Telephones

Item	Base Cabinet	Expansion Cabinet
Dimensions (H x W x D in inches)		
Cabinet	26 3/4" W x 10 7/8" D x 20 5/16" H (including top panel)	26 3/4" W x 10 7/8" D x 17 2/16" H (not including top panel)
Large-Display phone	4 1/8 x 7 3/8 x 9	
Other key phones	3 3/4 x 7 3/8 x 9	
DSL/T	3 1/8 x 7 3/8 x 9 1/8	
DSS/72	2 15/16 x 4 13/16 x 9 3/16	
EM/24	2 15/16 x 2 3/8 x 9 3/16	
Weight (lbs.)		
Cabinet	approximately 44 lbs.	approximately 44 lbs.
Large-Display phone	2.3 lbs.	
Other key phones	2.2 lbs.	
DSL/T	1.6 lbs.	
DSS/72	1.2 lbs.	
EM/24	.95 lbs.	

Resource Maximums

Line Capacities

System Resources	1 Cabinet	2 Cabinets	3 Cabinets	4 Cabinets	5 Cabinets	6 Cabinets
Ports (CO line or Station)	96	192	288	384	480	576
Speech Path Switching (CO line/Station)	Nonblocking					

Feature-Related Capacities

Resource	Maximum for					
	1 Cabinet	2 Cabinets	3 Cabinets	4 Cabinets	5 Cabinets	6 Cabinets
CPU Configuration	CPC-96	-----	-----	-----	-----	-----
	CPC-288			-----	-----	-----
	CPC-576					
Interconnection Cabling	-----	1	2	3	4	5
Loop Start Trunks	96	192	288	384	480	576
Ground Start Trunks	96	192	288	384	480	576
T-point ISDN-BRI (channels)	48	96	144	192	240	288
T-point ISDN-PRI (8/16/24ch.)	3	6	9	12	15	18
DID (Trunks)	96	192	288	384	480	576
T1 (8/16/24) (Trunks)	3	6	9	12	15	18
E&M (Tie-Lines)	48	96	144	192	240	288
AEC (Extensions)	96	192	288	384	480	576
DEC (Extensions)	96	192	288	384	480	576
S-point ISDN-BRI (channels)	48	96	144	192	240	288
S-point ISDN-PRI (channels)	3	6	9	12	15	18
EM/24 Unit	96	192	288	384	480	576
DSS/72 Console	12	24	36	48	60	72
3-Party Conference (no card required)	8	8	8	8	8	8
8-Party Conference (requires 1 CONF card per cabinet)	4	8	12	16	20	24
DTMF Unit	2	4	6	8	10	12
API Unit	1	2	3	4	5	6
Built-In ACD Unit	1	2	2	2	2	2
Built-In Voice Mail Unit	1	2	3	4	4	4
Traffic Condition	6 OHCS					
Speech Pass	Time division PCM method					
MCO Tenant Groups	12	24	36	48	60	72
MCO Trunk Groups	99	99	99	99	99	99
SSD Bins	800	800	800	800	800	800
PSD Bins	20	20	20	20	20	20
SSD/PSD String Length	24	24	24	24	24	24
SSD Name Length	16	16	16	16	16	16

Resource	Maximum for					
	1 Cabinet	2 Cabinets	3 Cabinets	4 Cabinets	5 Cabinets	6 Cabinets
PSD Name Length	7	7	7	7	7	7
Trunk Name Length	10	10	10	10	10	10
Extension Name Length	10	10	10	10	10	10
Attendant Group	1	1	1	1	1	1
Attendant Group Members	20	20	20	20	20	20
Ext. Hunt Groups	12	24	36	48	60	72
Ext. Hunt Group Members	20	20	20	20	20	20
External Page Port	1	1	1	1	1	1
External Relay Control Port	5	5	5	5	5	5
Message Waiting Set (High Priority) (per Ext.)	1	1	1	1	1	1
Message Waiting Set (Normal Priority) (per Ext.)	4	4	4	4	4	4
Hot Dial Pad Extensions (Digital)	96	192	288	384	480	576
Hot Lines	20	20	20	20	20	20
Virtual Ports	96	192	288	384	480	576
Extension COS	16	16	16	16	16	16
Trunk COS	16	16	16	16	16	16
TRS Class	50	50	50	50	50	50
ARS/TRS: Leading Digit Strings (max. 10 digits/string)	100	100	100	100	100	100
ARS/TRS: Follow Digit Strings (max. 8 digits/string)	500	500	500	500	500	500
ARS: Time List Tables	4	4	4	4	4	4
ARS: Time List Entries (per Table)	50	50	50	50	50	50
ARS: Route List Paths	100	100	100	100	100	100
ARS: Digit Modify Strings	50	50	50	50	50	50
Authorization Codes (UK use)	8	8	8	8	8	8
DID/DNIS Tables	2	2	2	2	2	2
DID/DNIS Numbers (per Table)	96	192	288	384	480	576
ISDN S-point DID Numbers	200	200	200	200	200	200
MSN Numbers	50	50	50	50	50	50
Closed Numbers	150	150	150	150	150	150
Tandem Exchange Numbers	50	50	50	50	50	50
Account Codes: Digit Length	10	10	10	10	10	10
Account Codes: Verified	500	500	500	500	500	500
Account Codes: Verified Digits	4	4	4	4	4	4
Call Pickup Groups	12	24	36	48	60	72
Paging Groups	10	10	10	10	10	10
Paging Group Members	72	72	72	72	72	72

Hardware Maximums

Part No.	Description	Maximum Quantity For					
		1 Cabinet	2 Cabinets	3 Cabinets	4 Cabinets	5 Cabinets	6 Cabinets
Station Equipment							
VB-44023	Switch Box	N/A	1	1	1	2	2
VB-44101	Voice Recognition Adaptor	96	192	288	384	480	576
VB-44210	16-key Standard Phone	96	192	288	384	480	576
VB-44220	22-key Standard Phone	96	192	288	384	480	576
VB-44223	22-key Small-Display Phone (2-line LCD)	96	192	288	384	480	576
VB-44224	22-key Small-Display Phone (2-line LCD) with voice recognition capability	96	192	288	384	480	576
VB-44225	22-key Large-Display Phone (7-line LCD)	96	192	288	384	480	576
VB-44230	34-key Standard Phone	96	192	288	384	480	576
VB-44231	34-key Small-Display Phone (2-line LCD)	96	192	288	384	480	576
VB-44310	24-key Expansion Module (EM/24)	48	96	144	192	240	288
VB-44320	72-key DSS/BLF Module (DSS/72)	12	24	36	48	60	72
VB-44884	7 ft. handset cord	96	192	288	384	480	576
VB-44885	15 ft. handset cord	96	192	288	384	480	576
VB-44886	25 ft. handset cord	96	192	288	384	480	576
VB-44890	K-type handset	96	192	288	384	480	576
Common Equipment							
VB-44181	SCC: service circuit card	1	1	1	1	1	1
VB-44410	CPC-96: call processor card	1	N/A	N/A	N/A	N/A	N/A
VB-444201	CPC-288: call processor card	1	1	1	N/A	N/A	N/A
VB-444202	TSW-288: time switch card	1	1	1	N/A	N/A	N/A
VB-444301	CPC-576: call processor card	1	1	1	1	1	1
VB-444302	TSW-576: time switch card	1	1	1	1	1	1
VB-44451	CBL: building-block expansion card	N/A	1	2	3	4	5
VB-44452	CBLDBS: connection cable card for DBS (1 per DBS cabinet)	N/A	1	2	2	2	2
Telephone Company Interfaces							
VB-43551	CID: Caller ID 8-circuit daughter board	12	24	36	48	60	72
VB-44460	SYNC: Sync Unit	1	1	1	1	1	1
VB-44510	LTRK/8: loop start trunk card (8-port)	12	24	36	48	60	72
VB-44511	LGTRK/8: loop-start/ground-start trunk card (8-port)	12	24	36	48	60	72
VB-44512	Trunk MDF Interface	10	20	30	30	30	30
VB-44520	DID: Direct Inward Dial trunk card (8-port)	12	24	36	48	60	72
VB-44530	BRI: Basic Rate Interface card (T-point)	12	24	36	48	60	72
VB-44540	PRI: Primary Rate Interface card (T/S-point)	3	6	9	12	15	18
VB-44550	T-1 Interface	3	6	9	12	15	18
VB-44560	E&M/4: E&M Tie Line trunk card (4-port)	12	24	36	42	60	72

Part No.	Description	Maximum Quantity For					
		1 Cabinet	2 Cabinets	3 Cabinets	4 Cabinets	5 Cabinets	6 Cabinets
Station Interfaces							
VB-44110	MFR/8: DTMF signal receiver for 8 SLT lines	1	2	3	4	5	6
VB-44610	DEC: digital extension card (8-port)	12	24	36	48	60	72
VB-44611	Extension MDF Interface	10	20	30	30	30	30
VB-446230	AEC: analog extension card (8-port)	12	24	36	48	60	72
VB-44630	BRI: Basic Rate Interface card (S-point)	12	24	36	48	60	72
VB-44540	PRI: Primary Rate Interface card (T/S-point)	3	6	9	12	15	18
Optional Equipment							
VB-43703	Power Failure Unit (4-line)	24	48	72	96	120	144
VB-44025	Built-in System Backup Battery Kit (2 batteries per kit)	1	2	3	4	5	6
VB-44130	API: Application Processor Interface	1	2	3	4	5	6
VB-44140	Built-In ACD Unit	1	2	2	2	2	2
VB-44150	Voice processing card/8-port (VM only)	2	4	6	8	8	8
VB-44160	Voice processing card/4-port (VM/ACD)	2	4	6	8	9	10
VB-44170	Built-In VM Unit	1	2	3	4	4	4
VB-44330	PC Attendant Console 96 (1 Ext. + 1 DSS per Console unit)	12	24	36	48	60	72
VB-44331	PC Attendant Console 384 (1 Ext. + up to 5 DSSs per Console unit)	2	4	7	9	12	14
VB-44332	PC Phone (1 Ext. per PC Phone unit)	96	192	288	384	480	576
(none)	PC Customize Tool	1	1	1	1	1	1

Note: These maximums are based on overall CO line capacities. They do not allow for CO lines used for outside lines.

Cabling Specifications

Maximum Cabling Distances

Loop Type Resistance	Resistance	Cable Gauge (AWG)	Maximum Cabling Length in Feet (distance from the DBS 576)
Key Telephone, EM/24	40 Ohms	22	1239
		24	779
		26	490
DSS/72	20 Ohms	22	619
		24	330
		26	245
SLT	100 Ohms	22	3097
		24	1948
		26	1225
Doorphone (loop between the DBS 576 and Doorphone Adapters)	10 Ohms	22	309
		24	194
		26	122
Doorphone (loop between the Doorphone Adapter and the Doorphone)	10 Ohms	22	1239
		24	779
		26	490

NOTE: If a TAPI box or Voice Response Telephone Adapter is installed with the telephone, the measured resistance must be less than 20 Ohms and the maximum cabling distance reduced in half compared to a standard key telephone.

Voice/Data Transmission

Voice Path from Digital Keyphones to the DBS 576

Channel	Speed
Overall communications path	256 kbps
D-channel data	16 kbps
B-channel data	64 kbps

Data Communication Ports

Port	Parameters	
Serial Port 1	Interface:	RS232-C
	Baud rate:	300, 600, 1200, 2400, 4800, 9600 Bps
	Parity:	Even, odd, none
	Stop bit length:	2 or 1
	Data bit length:	7 or 8
Maintenance (Built-in) (Emergency)	Baud rate:	300
	Stop bit length:	1
	Data bit length:	8
	Parity:	None
Serial Port 2	Interface:	RS232-C
	Baud rate:	300, 600, 1200, 2400, 4800, 9600 Bps
	Parity:	Even, odd, none
	Stop bit length:	2 or 1
	Data bit length:	7 or 8

Modem Speed Throughput

NOTE: The DBS 576 is capable of passing modem speeds up to 31,200 bps or less, depending on the type and quality of the trunks and facilities used.	
Modem Speed:	9,600 - 33,600 bps
Protocol:	ITU-T V.34
Error Control:	Enabled (ITU-T V.42)
Data Compression:	Enabled (ITU-T V.42bis)
Analog Ports	
AEC to AEC in the same switch:	28,800 bps (maximum) (Loss: 0 dB)
AEC to LS or GS Trunk in the same switch:	31,200 bps (maximum) - 16,800 bps (minimum) (Loss: 0 - 17 dB, 24 AWG)
AEC to DID Trunk in the same switch:	31,200 bps (maximum) - 21,000 bps (minimum) (Loss: 0 - 17 dB, 24 AWG)
AEC to E&M/2-Wire:	24,000 bps (maximum) - 9,600 bps (minimum) (Loss: 0 - 17 dB, 24 AWG)
AEC to E&M/4-Wire:	26,400 bps (maximum) - 14,400 bps (minimum) (Loss: 0 - 17 dB, 24 AWG)
Digital (ISDN) Ports	
BRI to actual line:	26,400 bps (maximum)
T-BRI to S-BRI:	28,800 bps (maximum)
T-PRI to S-PRI:	28,800 bps (maximum)

Signaling Characteristics

Signaling to CO

Item	Specification
Dial pulse	8 to 11 pulses per second
Break ratio	58% to 64%
Minimum pause	0.7 to 1.0 seconds
Trunk start signaling	Loop or ground start; E&M wink or immediate start

Transmission Specifications

Item	Specification
Impedance	600 Ohms
Overload level	600 Ohms
Insertion Loss	CO trunk to analog station
	Analog station to CO trunk
	CO trunk to digital station
	Digital station to CO trunk
	Digital station to digital station
	Digital station to analog station
	Analog station to digital station
	Analog station to analog station

DTMF Frequencies

Digit	Frequency (Hz)
1	700 + 1200
2	700 + 1340
3	700 + 1480
4	760 + 1200
5	760 + 1340
6	760 + 1480
7	860 + 1200
8	860 + 1340
9	860 + 1480
0	940 + 1340
*	940 + 1200
#	940 + 1480

Panasonic Telephone Systems



See More
Panasonic Manuals



www.voicesonic.com
Phone 877-289-2829